



# Eurobot<sup>Open</sup> Junior 2020 Rules

27<sup>th</sup> edition of the robotic contest - Eurobot  
OFFICIAL version



**NOTE:** all images in this document are provided as a guide to illustrate the various paragraphs. In no case they can serve as a reference. Only the dimensions, colors and materials indicated in the appendix shall be taken into consideration.

<b>A. NOTICE</b>	<b>3</b>
<b>B. CONTEST PRESENTATION</b>	<b>4</b>
<b>C. THEME PRESENTATION</b>	<b>6</b>
<b>D. PLAYING AREA AND ACTIONS</b>	<b>7</b>
D.1. IMPORTANT INFORMATION	7
D.2. PLAYING AREA	8
D.3. STARTING AREAS	9
D.3.a. DESCRIPTION	9
D.3.b. CONSTRAINTS	9
D.4. CREATE FAIRWAYS	10
D.4.a. DESCRIPTION AND LAYOUT OF THE PLAYING ELEMENTS	10
D.4.b. ACTIONS AND CONSTRAINTS	11
D.4.c. POINTS	11
D.5. LIFT UP THE WINDSOCKS	12
D.5.a. DESCRIPTION AND LAYOUT OF THE PLAYING ELEMENTS	12
D.5.b. ACTIONS AND CONSTRAINTS	12
D.5.c. POINTS	12
D.6. TURN ON THE LIGHTHOUSE	13
D.6.a. DESCRIPTION AND LAYOUT OF THE PLAYING ELEMENTS	13
D.6.b. ACTIONS AND CONSTRAINTS	13
D.6.c. POINTS	14
D.7. ANCHOR SAFELY	15
D.7.a. DESCRIPTION AND LAYOUT OF THE PLAYING ELEMENTS	15
D.7.b. ACTIONS AND CONSTRAINTS	15
D.7.c. POINTS	16
D.8. HOIST FLAGS	17
D.8.a. ACTIONS AND CONSTRAINTS	17
D.8.b. POINTS	17
D.9. ESTIMATE THE PERFORMANCE	18
D.9.a. DESCRIPTION AND LAYOUT OF THE PLAYING ELEMENTS	18
D.9.b. ACTIONS AND CONSTRAINTS	18
D.9.c. POINTS	18
<b>E. PROJECT PRESENTATION</b>	<b>19</b>
E.1. CONSTRAINTS	19
E.2. EVALUATION	19
<b>F. THE ROBOTS</b>	<b>20</b>
F.1. FOREWORDS	20
F.2. DIMENSIONS	21
F.3. ENERGY SOURCES	22
F.4. OTHER DESIGN CONSTRAINTS	22
F.4.a. THE WIRE CONTROL SYSTEM	23
F.4.b. THE WIRELESS CONTROL SYSTEM	23
F.4.c. THE CABLE	24
F.4.d. THE CONTROL SYSTEM FOR THE AUTONOMOUS SECONDARY ROBOT	24
F.5. SECURITY CONSTRAINTS	24

F.5.a. GENERAL ASPECTS . . . . .	24
F.5.b. LASERS . . . . .	25
F.5.c. HIGH POWER LIGHT SOURCES . . . . .	25
F.5.d. COMPRESSED AIR SYSTEMS . . . . .	25
<b>G. MATCHES</b>	<b>26</b>
G.1. PREPARATION TIME . . . . .	26
G.2. THE MATCH . . . . .	26
G.3. COUNTING POINTS . . . . .	27
G.3.a. CREATE FAIRWAYS . . . . .	27
G.3.b. LIFT UP THE WINDSOCKS . . . . .	27
G.3.c. TURN ON THE LIGHTHOUSE . . . . .	27
G.3.d. ANCHOR SAFELY . . . . .	27
G.3.e. HOIST FLAGS . . . . .	27
G.3.f. ESTIMATE THE PERFORMANCE (BONUS POINTS) . . . . .	27
G.3.g. THE PENALTIES . . . . .	28
G.3.h. BONUS POINTS . . . . .	28
G.3.i. FORFEIT CASES . . . . .	28
<b>H. THE CONTESTS</b>	<b>29</b>
H.1. GENERAL INFORMATION . . . . .	29
H.2. APPROVAL . . . . .	29
H.2.a. STATIC APPROVAL . . . . .	29
H.2.b. DYNAMIC APPROVAL . . . . .	29
H.2.c. SIGNIFICANT TECHNICAL MODIFICATIONS AFTER THE APPROVAL . . . . .	29
H.3. QUALIFICATION PHASE . . . . .	29
H.4. THE PLAY-OFF PHASE . . . . .	30
H.5. THE FINAL PHASE . . . . .	30
H.6. QUALIFICATION FOR THE NATIONAL MEETING . . . . .	31
H.7. QUALIFICATION FOR THE EUROPEAN MEETING . . . . .	31
<b>I. APPENDIX</b>	<b>33</b>
I.1. GENERAL DRAWINGS . . . . .	33
I.1.a. BUOYS . . . . .	34
I.1.b. ROCKY AREA AND LIGHTHOUSE . . . . .	35
I.1.c. WEATHERVANE . . . . .	36
I.1.d. GROUNDED ZONES . . . . .	38
I.1.e. WINDSOCKS . . . . .	39
I.1.f. PORT PROTECTION CLEATS . . . . .	41
I.2. MATERIAL REFERENCES . . . . .	42
I.3. MANUFACTURING TOLERANCES . . . . .	42
I.4. COLOUR REFERENCES . . . . .	43
I.5. MARITIME SIGNAL FLAGS . . . . .	44

## A. NOTICE

### WARNING!

**General remarks are annotated in the document. Please, pay special attention to these points.**

This year the rules have been split up. Most parts remain the same for the Eurobot<sup>Open</sup> and Eurobot<sup>Open</sup> Junior contests, but to avoid confusion, each contest has its own rules as a single document.

Thus the particular cases specific to one of the competitions appear only in the document concerning it.

You will find the Eurobot<sup>Open</sup> and the Eurobot<sup>Open</sup> Junior rules and other information on the Eurobot<sup>Open</sup> website (<http://www.eurobot.org/>)

**Please note that the version of this release is noted down at the end of this page. For any inquiry, only an official version should be considered.**

---

Changes or clarifications to the rules may be made during the year. We therefore strongly encourage all participants to check our website regularly (<http://www.eurobot.org/>) as well as your NOC's own website for news. You can also follow discussions, ask questions or get further assistance on our forum (<http://www.planete-sciences.org/forums/>).

Possible changes of the technical specifications will be announced on the Eurobot website, (<http://www.eurobot.org/>) or on the website of the National Organization Committee (NOC) in your country.

The forum responses from a referee are official responses taken into account for match refereeing and homologation stages.

In case of doubt regarding any point of the rules or the approval of robots, the referee committee may also be contacted at [referee@planete-sciences.org](mailto:referee@planete-sciences.org).

**Have a good reading!**

## B. CONTEST PRESENTATION

Eurobot<sup>Open</sup> and Eurobot<sup>Open</sup> Junior are two events addressed to young people interested in robotics. Teams are usually composed of students involved in an Eurobot<sup>Open</sup> school project, a group of friends, or independent robotics clubs. They share the same goal: to offer young people an active learning process, to put into practice their knowledge and soft skills during a fun and friendly event.

The rules for both events (Eurobot<sup>Open</sup> and Eurobot<sup>Open</sup> Junior) are based on the same concept. As organisers, we intend to provide a common platform for the Eurobot<sup>Open</sup> event. This platform is dedicated to autonomous robots for Eurobot<sup>Open</sup> while for Eurobot<sup>Open</sup> Junior, the robots are remote controlled. In this way, a Eurobot<sup>Open</sup> organiser can easily set up a Eurobot<sup>Open</sup> Junior contest and vice versa. Remember this when you will be organizing your official or unofficial event.

You're currently reading version  
**Eurobot<sup>Open</sup> Junior OFFICIAL**  
of 2020rules  
(this version concerns only the wire-guided robots)

Participants in the Eurobot<sup>Open</sup> Junior finals must be aged up to 18 years. Each team can have a supervisor to whom the age limit does not apply.

The technical challenge is to build a remote controlled robot as well as an optional autonomous robot.

**Be careful**, depending on your country's educational system, this age limit may be slightly different. Check the registration requirements stated by your National Organizing Committee.

A team is a group of young people who have built one or two robots for the event. A person can only represent one team. However, we encourage teams to share their expertise and knowledge.

An organization (club, school, etc.) can supervise and register several teams, if allowed by the registration requirements set by your National Organizing Committee. The acceptance of these requirements is compulsory to validate your registration and your entry.

The project can be supervised by someone over the age limit (teacher, parent, group leader, etc.), but all elements of the robot(s) must be designed by the participants. In this context, robots manufactured from a commercially purchased chassis or rolling base will not be accepted.

**In the event that a robot was imagined, built or modified by the tutor alone, organisers can disqualify or reject the participation of the team in the competition. Students must be capable of describing and explaining the manufacturing process of their robots. It is strictly forbidden that the tutor modifies the robot during the competition. He can in exchange advise the students and guide them.**

The objective of the secondary robot is to allow young people to experiment with programming. It is tolerated to use a commercial robotic base for this robot unlike the main robot. As the work is mainly on programming, it will be asked during the event that the students present the program and are able to explain it to the referees.

Eurobot<sup>Open</sup> and Eurobot<sup>Open</sup> Junior must take place in a friendly, fair-play spirit. As for every sport event, referees' decisions are pronounced without a possible recourse, except if an agreement between all stakeholders is met.

Eurobot<sup>Open</sup> and Eurobot<sup>Open</sup> Junior European finals gather teams selected after national qualifications. European finals take place in Europe, but all countries can participate. Countries where more than three teams are registered have to organize a national qualification to select teams that will attend the European finals.

**Common parameters can change from one year to another. Accordingly, please read the rules carefully even if the chapters may seem familiar to you (playing area dimensions, robots dimensions, starting area dimensions etc.).**

Robotics contests are public events. Therefore, we ask the teams to respect our rules of decency and safety (electrical, sound level, manners, etc.). These rules apply to the participants, their supporters and all the equipment they bring.

## C. THEME PRESENTATION

Prepare to set off on the high seas. In 2020, robots will explore the oceans and master the fine art of sailing.

You can rely on lighthouses and buoys to orient your ships. Plan your trip and bring us back stories of your journey.

May the winds blow in your sails!

Your missions will be:

- **Create fairways** to restore maritime traffic.
- **Lift up the windsocks** that have been swept away by the storm.
- **Switch on the lighthouse** so that lost boats can safely return to port.
- **Anchor safely** your robots in the mooring zones, safe from the wind, at the end of their journey.
- **Hoist your flags** to send messages to other ships.
- **Estimate your performance.**

**Warning!** All actions are independent from one another and no specific sequence is imposed whatsoever. No single action is compulsory. Give careful thoughts to your strategy. It is strongly recommended to design simple and reliable systems with a limited number of actions.



Figure 1 – Overview of the playing area

## ***D. PLAYING AREA AND ACTIONS***

### ***D.1. IMPORTANT INFORMATION***

Organisers are committed to building the playing area with as much accuracy as possible. Nevertheless, they reserve the right to do minor modifications and adjustments.

**No complaints regarding dimensional deviations will be taken into account.**

Teams are warned that the surface condition may differ from one playing area to another and may also degrade over time.



## D.2. PLAYING AREA

The playing area is a horizontal rectangular plan of 3000 mm by 2000 mm with borders of 70 mm height on each side. Depending on the carpenters, it may consist of one or more pieces (eg 3 pieces of 1000 mm per 2000 mm).

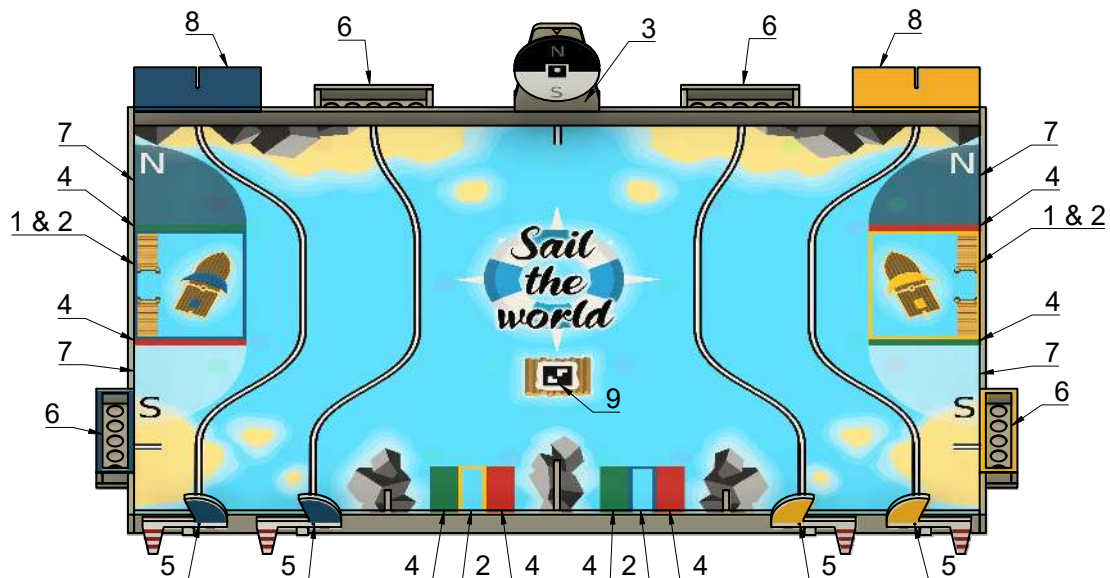

Figure 2 – Detailed view of the playing area

- |                   |                           |
|-------------------|---------------------------|
| 1. Starting areas | 6. Reefs                  |
| 2. Port           | 7. Mooring zone           |
| 3. Weather vane   | 8. Rocky areas            |
| 4. Fairway lines  | 9. ArUco marker number 42 |
| 5. Windsocks      |                           |

**Full specifications of the playing area and game elements (dimensions, positions at the beginning of the match, colors and other references) are listed in the appendix.**

**In the remainder of this document, horizontal and vertical directions are stated relative to the playing area. Notions of “left”, “right”, “front” and “back” are stated with respect to the spectator’s point of view.**

### D.3. STARTING AREAS

#### D.3.a. DESCRIPTION

Each team has a starting area for their robots. It is a rectangular surface delimited by a border of the team's color (the border is included in this zone).



(a) Blue starting area



(b) Yellow starting area

#### D.3.b. CONSTRAINTS

Before the beginning of the match, the vertical projection of the robots must not exceed the limits of the starting area.

Make sure your robots can fully enter the starting area. Overtaking above the lateral border but not beyond the playing area is allowed.

The starting area does not include the fairway lines.

Robots are not allowed to enter the starting area of the opposing team during the entire match.

#### D.4. CREATE FAIRWAYS

Among marine navigational markers, buoys are essential safety elements for any sailor. They are used to indicate areas of risk and to guide boats in their operations. Before arriving in ports, rows of green buoys to starboard and red buoys to larboard may be placed in such a way as to form fairways that signal the safe shipping lane to be followed by incoming and outgoing vessels. After a storm these buoys drifted onto the playing area, leaving the signage in disarray. Your robot-ships are therefore called upon to recover them and reform the fairways leading to the ports.

##### D.4.a. DESCRIPTION AND LAYOUT OF THE PLAYING ELEMENTS

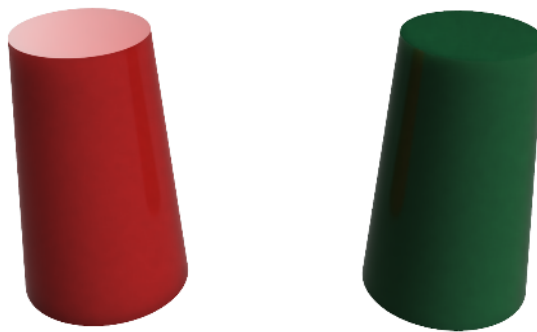

Figure 4 – Playing elements - The buoys

**The buoys:** There are 44 buoys on the table, represented by reusable plastic cups, half of them are red and the other half green. They are initially located on predefined places (cf. Figure 16):

- placed directly on the playing table, these buoys are called "adrift". The 4 buoys around each port are reserved to the owner of the port. The other 8 are available to everyone.
- either on:
  - reefs located along lateral borders, and reserved to the team with the closest starting area.
  - reefs in common for both teams, at the back of the table.

The buoys initially present in these reefs are called "grounded buoys". The sequence of the grounded buoys at the back is random (drawn from 3 possible combinations after the preparation phase). For the reefs located along the lateral edges, the order of the buoys is fixed (non-random), given by the Figure 16.

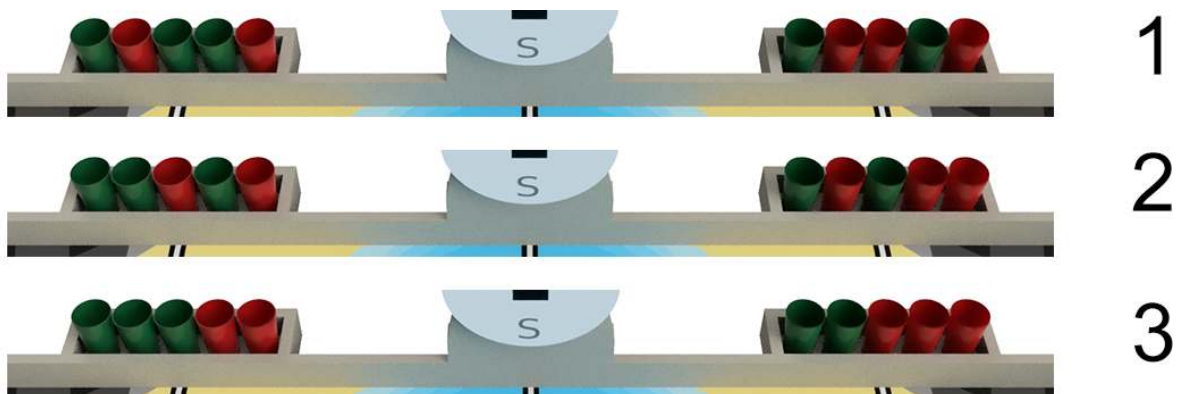

Figure 5 – Possible combinations of grounded buoys.

**Harbours:** these are areas that are the same colour as each team, each team has two:

- a "big" port, located along the lateral edge of the playing area;
- a "small" port, located at the front of the table.

**Fairways:** along each port, there are by two parallel lines, red and green respectively. They mark the fairways for each port. Note that these two lines are considered being included in the port.

#### D.4.b. ACTIONS AND CONSTRAINTS

**Actions:** Robots have to retrieve adrift or grounded buoys and place them in the fairways to restore the buoyage. Buoys must be placed on the fairways lines in the ports, and preferably sorted according to the colour of the line.

**Constraints:**

- For a buoy to be considered valid in a fairway line, at least one of its two circular planes (the "top" or "bottom" of the buoy) must be in full contact with the playing area and at least partially in contact with a fairway line (see Figure 6b).
- Each fairway is assigned to a team. It is therefore not accessible to the opposing team, which must under no circumstances move the buoys already positioned there.
- To be considered as being in the port, a buoy must be at least partially placed (by its vertical projection) in the port or on fairway lines, in any position with or without contact with the table (Cf. Figure 6a). A buoy still controlled by a robot after the end of the match will not be counted.

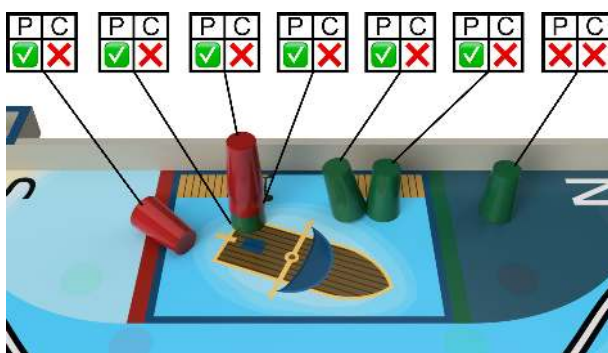

(a) Case of validity for buoys in ports and fairways. P=Port  
C=Fairway

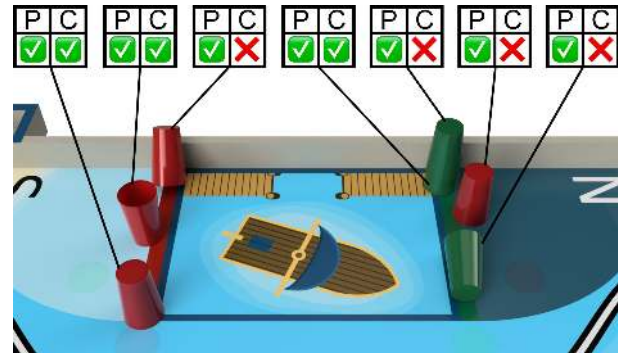

(b) Case of validity for buoys in harbour and channel. P=Port  
C=Fairway

#### D.4.c. POINTS

- **1 point** per valid buoy in the port;
- **1 point** additionally per valid buoy on the fairway line of its color;
- **2 points** per pair of valid buoys on the fairway lines of one port. A valid pair includes one green buoy and one red;

## D.5. LIFT UP THE WINDSOCKS

### D.5.a. DESCRIPTION AND LAYOUT OF THE PLAYING ELEMENTS



Figure 7 – Windsock

**Windsock:** located at the front of the table, on the side of the team's starting area. The windsocks was destabilized by the storm and must be lifted up. Each team has two dedicated windsocks.

### D.5.b. ACTIONS AND CONSTRAINTS

#### Actions:

- Lift up the windsocks

#### Constraints:

- Windsocks are dedicated to each team, a team is not allowed to lift up or to put down the opposing team's windsocks.
- To be considered valid, the windsock mast has to be vertical at the end of the game.

### D.5.c. POINTS

- **5 points** if only one windsock is lifted up by the end of the game;
- **15 points** if both windsocks are lifted up by the end of the game;

## D.6. TURN ON THE LIGHTHOUSE

### D.6.a. DESCRIPTION AND LAYOUT OF THE PLAYING ELEMENTS

**The rocky area:** is located at the back of the table, on the same side as the starting area of the team. The horizontal plane of the rocky area is at the level of the table border.

**The lighthouse:** is an element created by the team and locked on the rocky area during the preparation phase.

### D.6.b. ACTIONS AND CONSTRAINTS

#### Actions:

- The team must place its lighthouse on the dedicated area during the preparation time.
- During the game, the lighthouse must be activated, by any system involving physical contact with one of the robots.
- Once the lighthouse is activated, it must deploy and turn on a sweeping light source to signal the rocky area.

#### Constraints:

- The lighthouse should not be activated by an element external to the table (i.e. team members, remote control from the public, etc.). A lighthouse is considered activated if it has changed significantly in shape or appearance compared to the beginning of the match.
- The lighthouse can only be activated during the game and through contact with one of the team's robots.
- The activation of the lighthouse must be done at the time of contact, but the activation mode can be done by any means, including wireless.
- At no time should the vertical projection of the lighthouse exceed the limits of the rocky area.
- As a result, the lighthouse will have the following dimensional constraints:
  - Maximum depth: 222 mm
  - Maximum width: 450 mm
  - Maximum initial height: 300 mm
  - Minimum height of the light source (deployed): 700 mm
  - Maximum deployed height: 900 mm
- The lighthouse weight must not exceed 3 kg.
- The lighthouse should deploy vertically during the match. This deployment can only take place after the lighthouse has been activated.
- The horizontal plane of the rocky area has a 10 mm wide groove from the centre of the support to the middle of the rear side. This groove must be used to secure the lighthouse on the rocky area using an 8 mm diameter threaded rod and a wing nut.
- The lighthouse must remain activated and deployed even after the game ends.
- The lighthouse may contain a power supply. In this case, an emergency stop button (meeting the same specifications as the robot emergency stop buttons) that directly cuts off the power supply must be installed on the lighthouse. It must be clearly visible, easily accessible and must remain at a constant height. The lighthouse can be powered before the start of the match but without being activated.
- This action must not be dangerous for either the public, people around the table, the table itself or robots.
- The lighthouse may have a screen but it is only allowed to display information about the current match. It must not display videos, images, photos or advertisements.

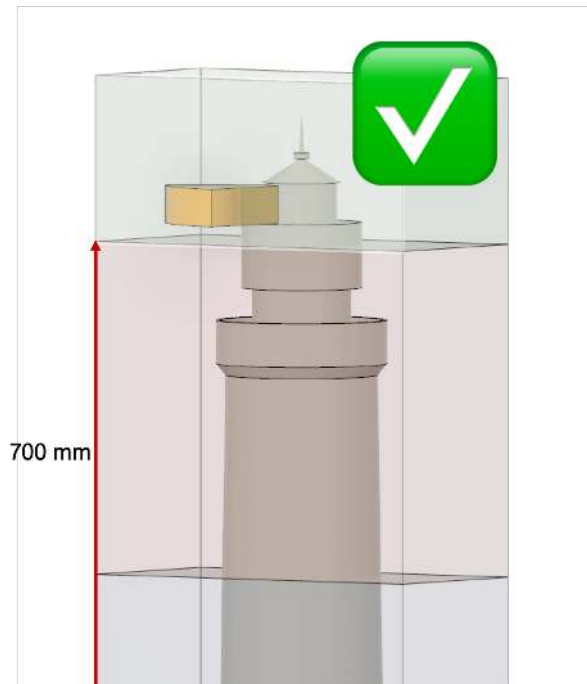
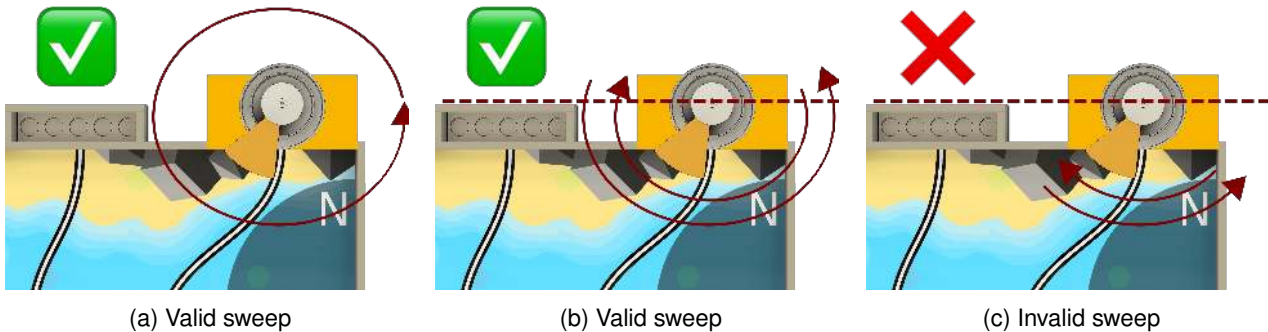

Figure 8 – Lighthouse deployment example

- Once turned on, the light from the lighthouse must be visible from the public, but must not dazzle anyone.
- The light of the lighthouse shall make an apparent or physical sweeping movement of the light source; the movement of a mask in front of the source is permitted. The sweep must be visible to the public by at least  $180^\circ$  of rotation with respect to the front of the table.



(a) Valid sweep

(b) Valid sweep

(c) Invalid sweep

#### D.6.c. POINTS

- **2 points** for putting the lighthouse on the rocky area before the game starts;
- **3 points** additionally for activating the lighthouse during the game;
- **10 points** additionally if the lighthouse is deployed, valid and its light activated by the end of the game.



## D.7. ANCHOR SAFELY

At the end of your journey, you need to go back to your mooring zone. Be careful to the wind direction before anchoring.

### D.7.a. DESCRIPTION AND LAYOUT OF THE PLAYING ELEMENTS

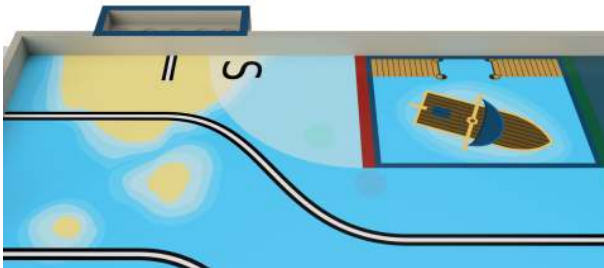

(a) South mooring zone

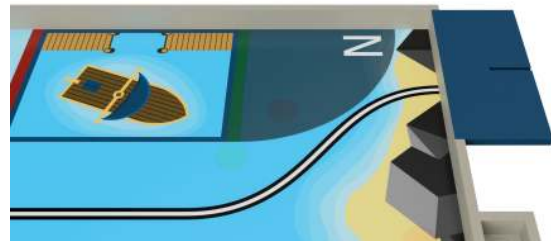

(b) North mooring zone

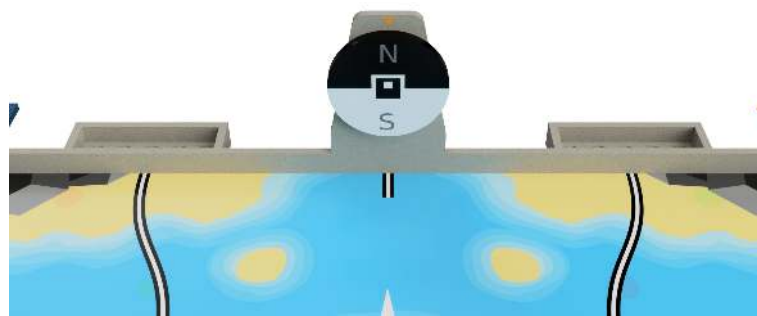

(c) Weathervane

**The weathervane:** Located at the center of the table, it stops rotating after the start of the match to indicate the wind direction. It is initiated by a referee at the very start of the game and stabilizes either on its North or South half. The rotation time is variable but will not exceed 25 seconds.

The weathervane is equipped at its centre of an ArUco label (4x4 number 17), 6 cm wide.

**Mooring zones:** Each team has two different mooring zones defined by arcs located on both sides of the starting area. These places are redundant of the weathervane compass points.

### D.7.b. ACTIONS AND CONSTRAINTS

**Actions:** At the end of the game, the main robot (controlled) robot should stop in the mooring zone indicated by the weathervane.

#### Constraints:

- Robots may come in contact with the weathervane, but it is strictly forbidden to change the position or stop it early.
- To be valid, the main robot (controlled) must have all or part of its vertical projection in the mooring zone.
- This action does not affect the secondary robot (autonomous) when it's present on the table.
- If the vertical projection of the main robot (controlled) exceeds in both mooring zones, the least advantageous zone will be counted.



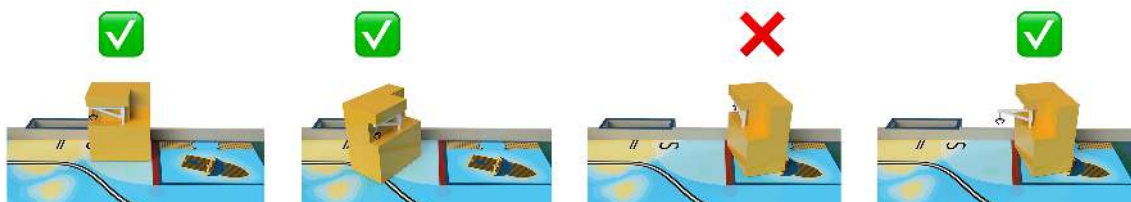

Figure 11 – Situation of validity in a mooring zone

#### D.7.c. POINTS

- **10 points** if the main robot (remoted) is valid in the mooring zone indicated by the weathervane;
- **5 points** if the main robot (controlled) is valid in the other mooring zone;

## D.8. HOIST FLAGS

### D.8.a. ACTIONS AND CONSTRAINTS

**Actions:** At the end of the game, between the 95th and the 100th second, your robots must hoist flags.

**Constraints:**

- Flags shall be identified as specified in the international maritime signal code; the only accepted flags are the letters.
- Each flag must have at least a minimum usable area of 30cm<sup>2</sup> (representing the significant content of the flag); but the ratio/dimensions can be freely chosen as long as this constraint is met. Each flag must be two-sided.

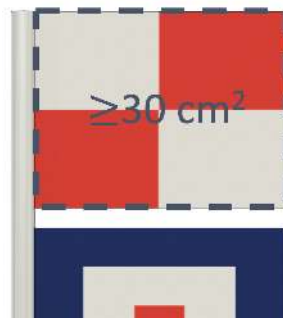
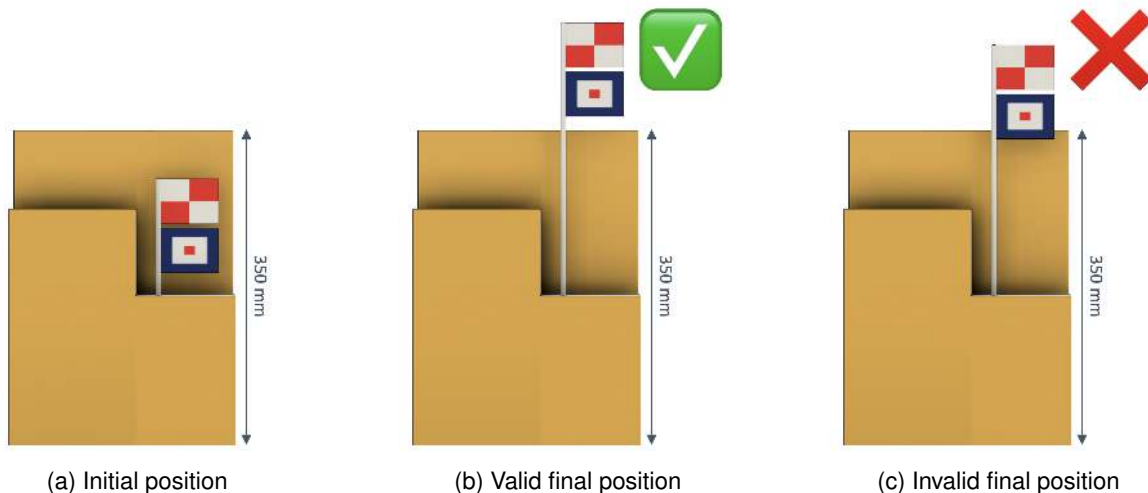

Figure 12 – Minimum dimensions for each flag

- At least two flags must be hoisted.
- When deployed, the flags must be easily identifiable by the public.
- The flags must be hoisted, fully at an altitude higher than 35 cm.



- During the last 5 seconds of the match, it's allowed that the flags and their actuators exceed the height limit of the robot, however not at any time they are allowed to cross the deployed perimeter of the robot.
- This action must not start before the 95<sup>th</sup> second and must be finished at the end of the match.

### D.8.b. POINTS

- **10 points** if at least one robot has raised its flags;

## D.9. ESTIMATE THE PERFORMANCE

### D.9.a. DESCRIPTION AND LAYOUT OF THE PLAYING ELEMENTS

The device for displaying the score estimation during the match must be made by the team:

- It can be static (sheet of paper, slate, etc.).
- Or dynamic (electronic display); located either on the robot or on the lighthouse (please make sure that the lighthouse is activated).

### D.9.b. ACTIONS AND CONSTRAINTS

- The team must evaluate the number of points scored in the match by its robot(s). For this, two exclusive options:
  - Pre-match evaluation on a static display: the team writes the score it intends to make during the match.
  - Evaluation during a match on a dynamic display device.
- The display area and its reading orientation must be easily visible and identifiable by the referees.
- The estimated score is an integer and must be expressed in decimal.
- It is allowed for a team with two robots to design a display for each robot. In this case, the score assessment will be the sum of the values of the two displays.
- In the case of dynamic displays, the estimated score must still be displayed after the end of the match.
- The score must not change after the match has finished, otherwise the bonus will be lost!
- In case of a dynamic display, the pilot control box can be used to update the display, but not to directly show the score.
- The copilot is not allowed to update the score estimation.

### D.9.c. POINTS

The assessment is based on all the previous actions (Create fairways, Lift up the windsocks, Turn on the lighthouse, Anchor Safely, Hoist flags).

The estimation bonus is calculated as follows: **Bonus = (0.3 x Score) - Delta**

- The score is the one scored by the team during the match on standard actions.
- The delta is the difference between the score made by the team during the match and the score estimated by the team. This one is always positive (Absolute value).
- The bonus is an integer value (rounded up).
- The bonus is added to the points of the team.
- A negative bonus is reduced to 0.
- A score of zero cannot give right to any bonus.

## **E. PROJECT PRESENTATION**

Both Eurobot<sup>Open</sup> and Eurobot<sup>Open</sup> Junior encourage participants to practice science in a funny and original way. Our main objective is to assist and value your projects conceived during the year. To achieve this, the teams must conceive a poster, and, organizers may require the teams to create a technical documentation of their robots.

We expect to see attractive, innovative robots that respect this edition's technical constraints and rules. Being creative and original will add value to your work as much as the performance of your robot(s) during the matches. By doing this presentation, you will increase the communication value of your project and the visual effect of your robots, for both the public coming to the events as well as for your own satisfaction. Having created something aesthetically and functionally complete, will strengthen your work attitude during and after the competition.

As in previous years, the presentation of your team's project (through project management on the long-term, task distribution ...) as well of your robots (technical systems implemented, chosen strategies ...) is an integral part of the event. Teams should present their projects in a way that is easily understandable and visible to the general public and the rest of the participants.

### **E.1. CONSTRAINTS**

This presentation must be made on a panel size A1 (594 x 841 mm) at least. If you want to use other visual media than paper, it is quite possible. Let your imagination be free!

On the other hand, we advise teams to hold a blog explaining progressively the progress of the realization of their robot ("logbook"). The creation of this blog can be done automatically when the team register on our Poolzor software, and the procedure to be followed is explained in detail on the platform. A blog is not mandatory to validate the registration, but we strongly encourage teams to do so, in order to promote the exchange of ideas around their projects.

### **E.2. EVALUATION**

The project must be exposed to the referees and / or guardian angels during the homologation of the robot to allow the teams to show all their work. This presentation will be taken into account in the homologation sheet.

During the meetings, a jury will pass through each panel and discuss with the teams to award a special prize for the best presentation. Team members must be able to present their project in English and/or in French, in order to compete for these prizes.

## F. THE ROBOTS

### F.1. FOREWORDS

Each team is allowed to register a maximum of two robots, called respectively "main robot" and "secondary robot". Each one have identical dimensional constraints. The set of both robots have additional dimensional constraints.

For Eurobot<sup>Open</sup> Junior, the principal robot is wire-guided or remote controlled and the secondary robot is autonomous.

**The construction of a secondary robot is optional. The aim is to allow teams with a large number of members to work on a second project. It is recommended for beginning teams to concentrate on building a single functional machine. Having one robot that works well is better than having two that do not move.**

A secondary robot can compete only with the main robot with which it was designed and approved. However it can compete alone if the main robot cannot participate. It cannot be re-approved with another main robot.

A team's main or secondary robot must not block the other team's robots. In the event of a voluntary action of this type indicated by the referee, the team may be penalized.

A robot must not intentionally cause damage to the opposing robots or to the playing area and its elements.

Only two team members are allowed to enter the backstage and on stage. They transport all the equipment (robots, beacons, etc.). The path to the playground may include stairs, especially when entering the stage. It is therefore recommended to design easily transportable equipment.

The main and secondary robots must be made up of elements that are fixed to each other (so robots cannot leave parts or elements on the playing area), with the exception of the playing elements.

Robots must not attach themselves to the playing area (e.g. with a suction cup).

A robot must not prevent the opponent from scoring points. A robot that remains static (e.g. if it has finished all its actions) must move to a location that does not disturb the opponent, otherwise it risks getting penalties!

A game element can be moved:

- for the purpose of scoring points with;
- if justified by performing another game action (e.g. if a common game element is located on the robot's path). The number of elements that are then moved (especially from their position at the beginning of the game) must remain minimal.

Deliberately vibrating the table or any other irregular action exposes the team to a refusal of approval.

Each team must design a unique and original set of robots under risk of disqualification. It is therefore not allowed to design robots that are significantly similar to robots of other teams (e. g. identical rolling bases or actuators). In case of doubt, contact the refereeing committee.

**Be imaginative!** For example, as an innovation but also to offer the public and the media an attractive show, your robot can use sounds, display expressions, etc.!

## F.2. DIMENSIONS

**Warning:** the dimensions of Eurobot<sup>Open</sup> robots are identical to those of Eurobot<sup>Open</sup> Junior. Eurobot<sup>Open</sup> Junior participants can more easily access the Eurobot<sup>Open</sup> meetings. The Eurobot<sup>Open</sup> Junior robot will only need modifications to make it autonomous.

### Dimensions of the robots :

The perimeter of a robot is the perimeter of the convex shell of its vertical projection on the ground. It is measured by surrounding it as shown in the illustrations below:

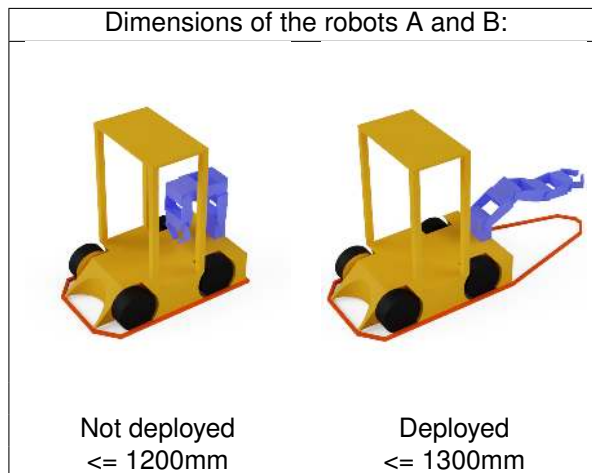

The perimeter of a robot must not exceed 1200 mm at the departure time. The perimeter of the fully deployed robot shall not exceed 1300 mm during the match. It is allowed to change the convex hull shape during the game, as long as the perimeter of this one always respects the maximum perimeter constraint.

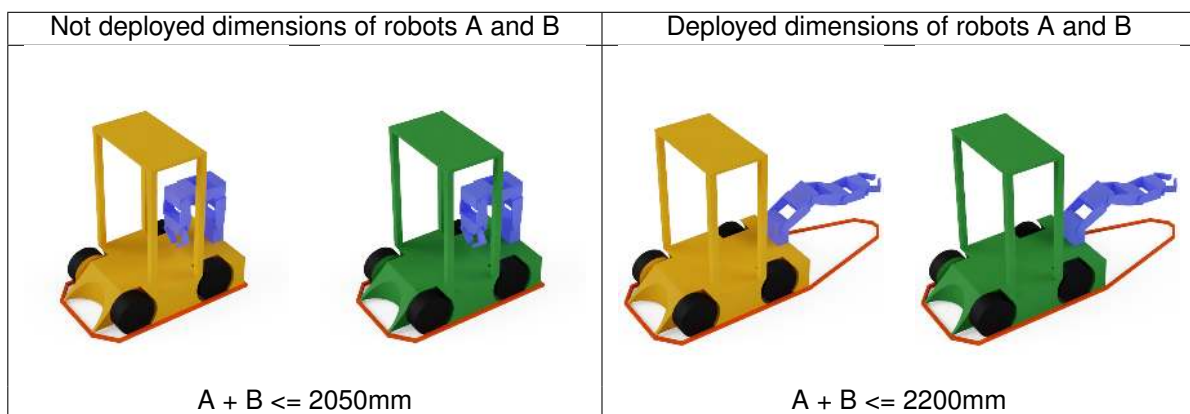

The sum of the perimeters of the two robots at the start of the match must not exceed 2050 mm. The sum of the deployed perimeters of the two robots must not exceed 2200 mm. Be careful, the sum of the deployed perimeters is equal to the sum of the maximum of the deployment perimeter of each of the two robots during the entire duration of the match. A robot cannot therefore reduce its perimeter during the match to allow a second robot to deploy more.

If a physical connection (mechanical, electrical, magnetic,...) exists between two robots of the same team, then the group formed by the two robots is in fact considered, for the perimeter constraints, as a single robot, until the group is dissociated. Note that a simple contact is not considered a physical connection.

At any time during the match the height of each robot must not exceed 350 mm. However, it can be tolerated that the emergency stop button exceeds this limit height to reach 375 mm. The flags are also allowed to exceed the 350 mm limit as long as they do not deploy before the 95<sup>th</sup> second.

### F.3. ENERGY SOURCES

All potential sources of energy stored in the robots and other secondary systems are permitted (batteries, springs, compressed air, gravitational energy, etc.), with the exception of sources of energy using chemical reactions such as combustion or pyrotechnics processes, which are prohibited for safety reasons. It is obvious that the use of living beings is strictly forbidden.

In addition, the use of corrosive products is strictly prohibited and liquid splashes are not permitted.

If you have any doubt about unconventional energy sources, ask the referees' committee as soon as possible, providing the corresponding datasheets.

In order to avoid any risk of fire, attention should be paid to the diameters of the wires, depending on the intensity of the currents flowing through them. It is also strongly advised to protect the electrical installation with a fuse, wired close to the batteries.

#### **Batteries:**

If the team chooses a battery power supply, we remind that only unmodified batteries can be used.

Teams must be able to play three games in a row. Note that this includes the time required to set up, during which the robot will be powered and awaiting the start.

Therefore, we strongly recommend that teams bring several sets of batteries and provide easy access to them in the robot for their replacement. Teams are reminded that it is essential to have a set of spare batteries, fully charged and available at all times.

#### **Note on the use of Lithium-based batteries:**

Lithium batteries are known for their lack of stability and can easily ignite when certain precautions are not taken.

This type of battery is therefore authorized under the following conditions:

- Suitable battery charger, which must be submitted for approval.
- Batteries kept in certified and unmodified fireproof bags (whether in the robot or on the stand, even in storage).
- A system for detecting underloads is highly recommended.
- Exception in the case of the following batteries, authorized without the conditions listed above:
  - Lithium batteries for LEGO Mindstorm / laptop / mobile phone, provided that they have not been dismantled and are used for the intended purpose of the manufacturer.
  - Lithium-Iron batteries (LiFePo4)

Warning! The supply systems must be easily transportable. Teams may have to go up and down the stairs on their way to the stage where the matches take place.

The power source transmitted to the robot can only be electric. The maximum permissible voltage is 13.8 V (measured between any two wires of the cable and the robot). This voltage source is not provided on the day of the meeting. On the other hand, the teams have access to the standard (230 V 50 Hz standard) and can use batteries.

The terminals of the cables must be insulated.

### F.4. OTHER DESIGN CONSTRAINTS

**Visibility:** A rectangular space of 100 x 70 mm per robot must be left free on one of the side faces. As far as possible, this space must be visible from a camera located at the height of the playing field. It must also be visually accessible during the majority of the match. The teams will receive stickers printed by the organization

(team number, sponsors etc), which they have to place on these open spaces.

Teams are strongly encouraged to make all element manipulations visible from the outside. By doing this, you allow the audience and the cameras that film the event to see how the transport of your game elements works.

**Starting cord of autonomous robots:** Robots must be equipped with a starting device easily accessible. This device has to be triggered by pulling the end of a cord at least 500 mm long. This cord must not stay attached to the robot after departure.

No other starting system (remote control, manual rocker switch, etc.) will be approved.

The start of one robot can launch the other robot.

**Emergency stop button of autonomous robots** Autonomous robots must be equipped with a red emergency stop button of at least 20 mm in diameter. It must be placed on the top of the robot in a visible position and in a non-risking area to be immediately accessible by the referees at any time during the match.

In its higher state, the button may exceed the robot's height by 25 mm. The emergency stop button must be operated by a simple downward movement (for example, by hitting it with the fist).

Pressing this button must stop all robot actuators immediately !

**Automatic shutdown** Each robot must be equipped with a system that stops the movement of the robot and all its actuators automatically at the end of the 100 seconds (a match's duration). The dynamic displays that are present on the robots, can remain on.

The automatic shutdown of the robot (s) is optional for participants in Eurobot<sup>Open</sup> Junior.

**Avoidance system (optional for Eurobot<sup>Open</sup> Junior)** Robot(s) avoidance systems are optional for Eurobot<sup>Open</sup> Junior participants.

**Warning: As most of the events are filmed, please adapt your avoidance systems so that it is not disturbed by autofocus cameras and filming.**

**Control system** For the main robot, each team must have a control console operated by a single driver.

**!!!New!!! For the first time, it is authorized to pilot your main robot by a wireless remote control. Both solutions, wired and wireless, are allowed this year. Please, read the next paragraphs to know the conditions.**

#### **F.4.a. THE WIRE CONTROL SYSTEM**

**The control system** It's the housing used for controlling the electrical devices of the robot. It is connected to the robot only by an electric cable. Any other communication type system between the robot and the outside, is strictly forbidden.

#### **F.4.b. THE WIRELESS CONTROL SYSTEM**

It is a housing for controlling the controlled robot's electrical devices. It communicates with the robot using wireless equipment. It can be connected to the robot by an electric cable to power it. The wireless control system should only be used for communication between the pilot and the robot. Under no circumstances should it be used to communicate with the outside world during matches.



To avoid interference problems with another team, the public or the equipment used by the organizer, it is strongly recommended that a team choosing a wireless control system be able to quickly change the frequency and/or communication channel. Under no circumstances may the team contest the inconvenience caused by possible interference.

#### **F.4.c. THE CABLE**

The electrical cable connecting the robot to its control system is not provided: it must be designed and implemented by each team, according to its needs.

The robot executes a lot of movements on the playing area, therefore the cable must have a minimum length of: two meters between the power outlet and the power supply and five meters between the robot and the control box.

The cable must come out from the top of the robot, so that it does not touch the playing area.

It is held in the air by the co-pilot using a pole provided by the organizers.

During the match, the co-driver must not interfere in the control or in the settings of the robot (supply voltage for example). Consequently, the departure of the secondary robot can only be triggered by the pilot.

The cable must not be used to guide the robot, or direct it in case of reversal. Penalties can be given to co-pilots that use the cable to guide their robot !

#### **F.4.d. THE CONTROL SYSTEM FOR THE AUTONOMOUS SECONDARY ROBOT**

Teams can use any kind of control system for the robot (analog, microprocessor-based, microcontroller, embedded computer, programmable logic, etc.).

These systems must be fully integrated into the secondary robot.

The control system must allow the robot(s) to play a match with either one of the colors provided to teams. Ideally, it should be configured shortly before the match with any of the two colours.

##### **Wifi networks:**

**At multiple contest locations, the number of active Wifi devices can disturb the robots implementing this technology for communication. To answer this issue, it's recommended (but not mandatory) to use the 5 GHz frequency rather than the 2.4 GHz one.**

### **F.5. SECURITY CONSTRAINTS**

#### **F.5.a. GENERAL ASPECTS**

All systems (robots and accessories) must comply with the European standards. This is also mandatory for the countries outside the EU that are organizing national meetings or send independent teams for the European Finals. Among other things, these security standards must respect safety rules and must not endanger participants, organizers nor public.

Robots must not have protruding or pointed parts that could be dangerous or cause damage.

The use of liquid, corrosive, pyrotechnic and living beings is prohibited.

All robots must comply with standard "low voltage" regulations. As a result, **the on-board voltages must not exceed 48 V.**

Potential differences greater than 48 V may exist, but only within closed commercial devices (eg lasers, LCD backlights, etc.) and only if these devices have not been modified and comply with national and European regulations.

In general, any system deemed by the referees' committee as dangerous will not be approved, and must be replaced, in order to be accepted in the competition.

#### **F.5.b. LASERS**

Only laser systems and classes defined according to the IEC60825 international standards are accepted. Teams using lasers must provide the manufacturer's document mentioning **the class of the device** (this information is normally always available on the system itself).

On the basis of this classification, class lasers:

- 1 and 1M are accepted without restriction
- 2 are tolerated only in case the laser beam do not exceed the play area
- 2M, 3R, 3B and 4 are strictly forbidden.

**WARNING: Disassembling or modifying devices using laser sources often results in a change of class. Laser devices must not be altered and only be used in the state of their commercialization (laser device = source + optics + electronics).**

#### **F.5.c. HIGH POWER LIGHT SOURCES**

When using a high intensity light source, the light intensity must not be dangerous to the human eye in case of direct contact. Note that some types of LEDs have warnings. Be responsible, as your machines are evolving in front of a general audience!

In the case of slightest doubt, the organization reserves the right to request the manufacturer's specifications to verify the non-dangerous nature of the lighting system used. If it turns out that the system is potentially dangerous, it may result in revocation of lasers class 2M and more.

#### **F.5.d. COMPRESSED AIR SYSTEMS**

Compressed air systems should not exceed 4 bars.

## G. MATCHES

The matches have a duration of 100 seconds.

Only two persons per team are permitted to go backstage and on stage to play the matches.

To ensure that the contest runs smoothly, we ask the teams to be present on their booth with the robot(s) and ready to go 30 minutes before the start of the series and until that the game is played.

In case of a problem, it is tolerated by the organization to ask for a delay to go to the match but this delay can never exceed the end of the current series. If the team cannot do its match before the end of the series, a forfeit will be applied. In case of abuse, a warning will be applied, and if the problem recurs in a subsequent series, a penalty may be awarded.

In any case, the team must be present on its booth when the organization comes to pick it up for a game. In the event of non-compliance with this rule, an official may initially give the team a warning, and if the absence is repeated on a subsequent series, a penalty may be awarded.

### G.1. PREPARATION TIME

At the start of a match, the elements of the playing area and the playing area itself are installed as indicated in the diagrams in the appendix.

Upon arrival on the playing area, each team has a maximum of three minutes to proceed with the placement of the robots and other equipment.

A robot which is not ready at the end of this period exposes the team to a forfeit for the match.

Besides, the other team's robots will still play their own game on the playing area. The team will have to score points to be declared the winner.

When both teams have finished setting up, or when the preparation time is over, the referee asks the participants if they are ready. From this moment, teams are no longer allowed to touch their robots. No dispute can be made on the disposition of the elements of play after the beginning of the match.

### G.2. THE MATCH

At the signal of the referee, each robot is switched on. In no case may robots, playing elements and playing area be allowed to be touched during the match. In case of absolute necessity, the referee may authorize such action.

Any manual intervention on a robot, a playing element or the playing area, without the explicit authorization of the referee, may justify the application of a forfeit or a penalty for the match.

No elements taken out of the playing area can be put back on the table before the end of the match and the validation of the scores.

At the end of the match, the robots must stop and turn off all their actuators. It is allowed to keep on any dynamic displays.

At the end of the match, **no one except the referee** can touch the robots and the playing elements unless expressly indicated by the referees. The referees count the points; they give the result of the match, including the points to the teams. If they both agree, they validate the match sheet, can take back their robot(s) and join their booth. If the teams do not agree, they refer calmly to the referees. The robots remain in place until the dispute is resolved. Refereeing decisions are final.

In the event of a situation that is difficult to judge, the referees reserve the right to decide whether or not to

replay the match.

The referees are allowed to pronounce the end of a game in advance, before the end of the regular time if both teams agree (if the robots are blocked for example).

A team is considered to be **forfeit** for the match:

- if none of the robots have completely left the starting area during the match,
- following refereeing decisions.

Pressing the emergency button of a robot during a match may expose the team to a penalty or a forfeit.

### **G.3. COUNTING POINTS**

At the end of the match, the referees count the points of each team according to the following.

#### **Points summary**

##### **G.3.a. CREATE FAIRWAYS**

- **1 point** per valid buoy in the port;
- **1 point** additionally per valid buoy on the fairway line of its color;
- **2 points** per pair of valid buoys on the fairway lines of one port. A valid pair includes one green buoy and one red;

##### **G.3.b. LIFT UP THE WINDSOCKS**

- **5 points** if only one windsock is lifted up by the end of the game;
- **15 points** if both windsocks are lifted up by the end of the game;

##### **G.3.c. TURN ON THE LIGHTHOUSE**

- **2 points** for putting the lighthouse on the rocky area before the game starts;
- **3 points** additionally for activating the lighthouse during the game;
- **10 points** additionally if the lighthouse is deployed, valid and its light activated by the end of the game.

##### **G.3.d. ANCHOR SAFELY**

- **10 points** if the main robot (remoted) is valid in the mooring zone indicated by the weathervane;
- **5 points** if the main robot (controlled) is valid in the other mooring zone;

##### **G.3.e. HOIST FLAGS**

- **10 points** if at least one robot has raised its flags;

##### **G.3.f. ESTIMATE THE PERFORMANCE (BONUS POINTS)**

The assessment is based on all the previous actions (Create fairways, Lift up the windsocks, Turn on the lighthouse, Anchor Safely, Hoist flags).

The estimation bonus is calculated as follows: **Bonus = (0.3 x Score) - Delta**

- The score is the one scored by the team during the match on standard actions.

- The delta is the difference between the score made by the team during the match and the score estimated by the team. This one is always positive (Absolute value).
- The bonus is an integer value (rounded up).
- The bonus is added to the points of the team.
- A negative bonus is reduced to 0.
- A score of zero cannot give right to any bonus.

**Warning! An element controlled by a robot, does not yield points. An element is considered to be controlled by a robot, if by moving the robot along its natural axis of movement the element is moved.**

### **G.3.g. THE PENALTIES**

A penalty is a **loss of 20 points** on the result of the match. Several penalties can be applied.

A negative score will be reset to 0.

#### **RECALL:**

**The penalties are intended to compensate for damage after a possible incident during the course of the game. A penalty situation is considered as non-respect of the rules of the game, this type of situation must remain exceptional!!! A penalty may result in the team's forfeit. The referees' committee will also be attentive to the penalties distributed between several levels of meeting (regional/national/European).**

### **G.3.h. BONUS POINTS**

5 bonus points are awarded to all teams that are not "forfeit".

### **G.3.i. FORFEIT CASES**

The score of a forfeit team is reset to zero.

## **H. THE CONTESTS**

### **H.1. GENERAL INFORMATION**

The Eurobot<sup>Open</sup> Junior meetings can be organized on three levels:

- regional: when they exist (e.g. in France, Eurobot<sup>Open</sup> Junior), qualify a number of teams for the national meeting,
- national: it allows to qualify the teams for the European meeting,
- European: this last stage brings together, in the same friendly spirit, teams from different countries in Europe and elsewhere.

Each meeting has several successive steps:

- The static and dynamic approvals of all the robots;
- A qualification phase;
- An optional play-off phase;
- A final phase.

### **H.2. APPROVAL**

#### **H.2.a. STATIC APPROVAL**

Before the start of the matches, robots are subject to the supervision of a referee who checks their compliance with the rules. Robots must be able to easily show all their mechanisms.

The ancillary systems (accessories, control panel, etc.) will also be subject to static control (size, mass, presence of mandatory elements, etc.).

#### **H.2.b. DYNAMIC APPROVAL**

The robots must, within 100 seconds, validate at least one action. The robots are put in a game situation but without the presence of an opposing team. Certain specific features provided for in the regulation can also be checked (timer, avoidance of opponents, etc.).

If the assembly consisting of the main robot and the optional secondary robot fulfills these conditions, it is declared approved.

#### **H.2.c. SIGNIFICANT TECHNICAL MODIFICATIONS AFTER THE APPROVAL**

It is essential to inform the referees of any significant modifications (functional, structural, dimensional ...) brought to the robot(s) or any other element after approval. The referees will then check the modifications made and re-approve the robot if they deem it necessary. In the event of a breach, the team may be declared disqualified from the contest.

### **H.3. QUALIFICATION PHASE**

During the qualification phase, the registered teams will have the possibility to play at least three games (often more, depending on the local organizers).

A ranking is established according to the accumulated points in order to select the qualified teams for the next phase.

The tied teams are tied by comparing their scores without taking into account their bonus points. Organizers may also use additional matches.

At the end of the qualifying phase, the 4, 8 or 16 first teams (according to the matches) are qualified for the next phase.

#### **H.4. THE PLAY-OFF PHASE**

An additional play-off phase may set up in the event that a meeting hosts two contests, the first of which qualifies for the second. For example:

- a regional meeting (A) and its national meeting (B)
- or a national meeting (A) and the European meeting (B)

The organizer may carry out the qualifying phase of both matches (A) and (B) either in parallel fashion or in a mixed fashion. In this case, a play-off phase may be organised in order to allow teams from the match (A) to qualify for the match (B), exempting them from having to catch up on all the matches from the qualifying phase of (B) in favour of this play-off phase.

The teams participating in this play-off phase are:

- the teams of the match (A), in a number corresponding to its qualification quota, and chosen in the order of ranking at the end of the qualification phase of (A) or through the award of a jury prize.
- the teams of the match (B), in a number equivalent to the participants in this phase from (A), chosen from among the last teams normally qualified for the final phase of the match (B).

**Example for a national meeting qualifying three teams for its European final with two teams qualified in the ranking and one per jury prize and whose European final phase has 16 teams. The teams participating in the play-off phase are:**

- **the first two teams of the national meeting at the end of the final phase of the national meeting, as well as the team that received the jury prize;**
- **and the teams ranked 16th, 15th and 14th in the qualifying phase of the European meeting.**

In this play-off phase, one match will be played for each participating team. The participating teams from the match (A) qualified through the ranking will play, in order of their ranking, with the teams from the match (B) with the lowest ranking. And the team(s) of (A) qualified for this play-off phase through a jury prize will play against the top-ranked teams of (B) in a random order.

Each team that wins its play-off match will be included in the main draw of the final phase of the match (B). At the end of the play-off phase, the tree of the final phase of the match (B) presented in Figure 14 may be revised to more accurately represent the level of each team.

#### **H.5. THE FINAL PHASE**

At the end of the previous phase, the qualified teams form the table of the matches of the final phase.

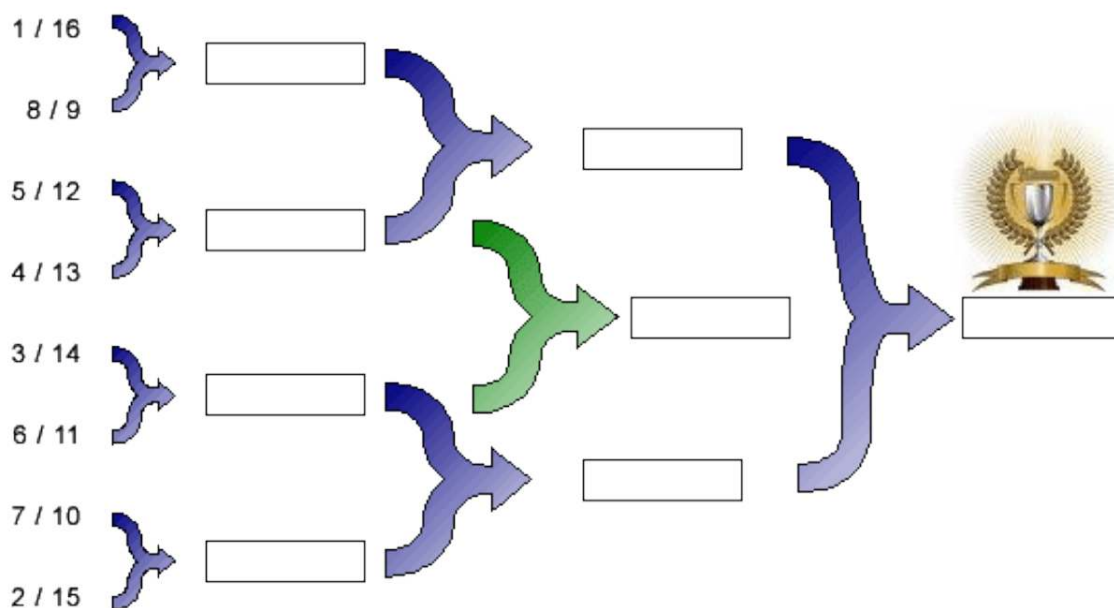

Figure 14 – Example of the tree for the final phase

The matches of the final phase are with knockout, unless otherwise organized on some meetings. In the event of double forfeit, double defeat or tie, the match is replayed immediately; if this second match is still a case of double forfeit, double defeat or equality, the winner is determined according to the points acquired at the end of the qualifying phase.

The final is played in two winning games. Be careful to provide batteries accordingly for autonomous robots.

#### H.6. QUALIFICATION FOR THE NATIONAL MEETING

When there are regional meetings, the number of teams qualified per regional meeting is proportional to the total number of teams registered at the national level.

The best teams in the ranking established at the end of the qualifying phase of each regional meeting, as well as at least one team chosen by the organizers from the special prizes (e.g. creativity, fair play, presentation, etc.).

#### H.7. QUALIFICATION FOR THE EUROPEAN MEETING

Each country participating in Eurobot<sup>Open</sup> Junior organizes a national meeting to determine the qualified teams for the international meeting.

The top teams in the final rounds (and not the qualification rounds) as well as the team who receives a special award will qualify for the European meeting. The number of qualified teams per country is proportional to the total of international registered teams.

**For questions and comments, feel free to visit the Planète Sciences Forum.**

<http://www.planete-sciences.org/forums/>

**News and more information about Eurobot<sup>Open</sup> and Eurobot<sup>Open</sup> Junior are available on our website**

[www.eurobot.org](http://www.eurobot.org)

**(It also contains links to your local organization)**

The whole organization team of Eurobot<sup>Open</sup> and Eurobot<sup>Open</sup> Junior wishes you a lot of fun and success in the



coming months, and looks forward to seeing you soon around our playing areas!

Robotic Regards,

The Eurobot<sup>Open</sup> Eurobot<sup>Open</sup> Junior organization committee.

# I. APPENDIX

## I.1. GENERAL DRAWINGS

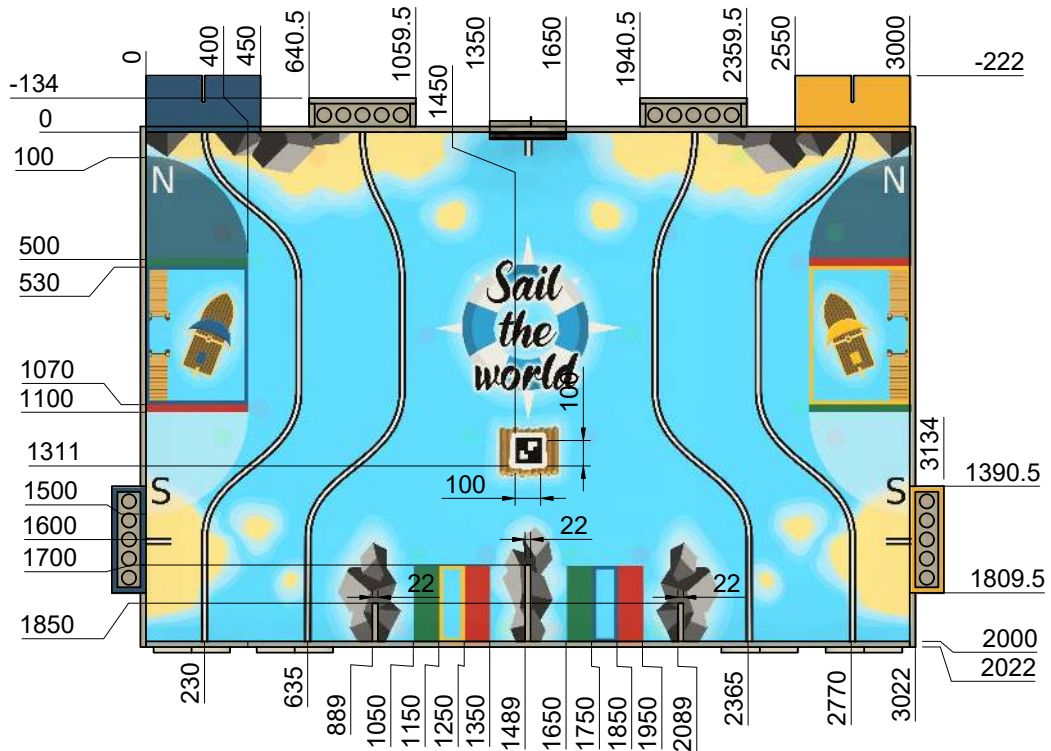

Figure 15 – Top view of the playing area without the buoys

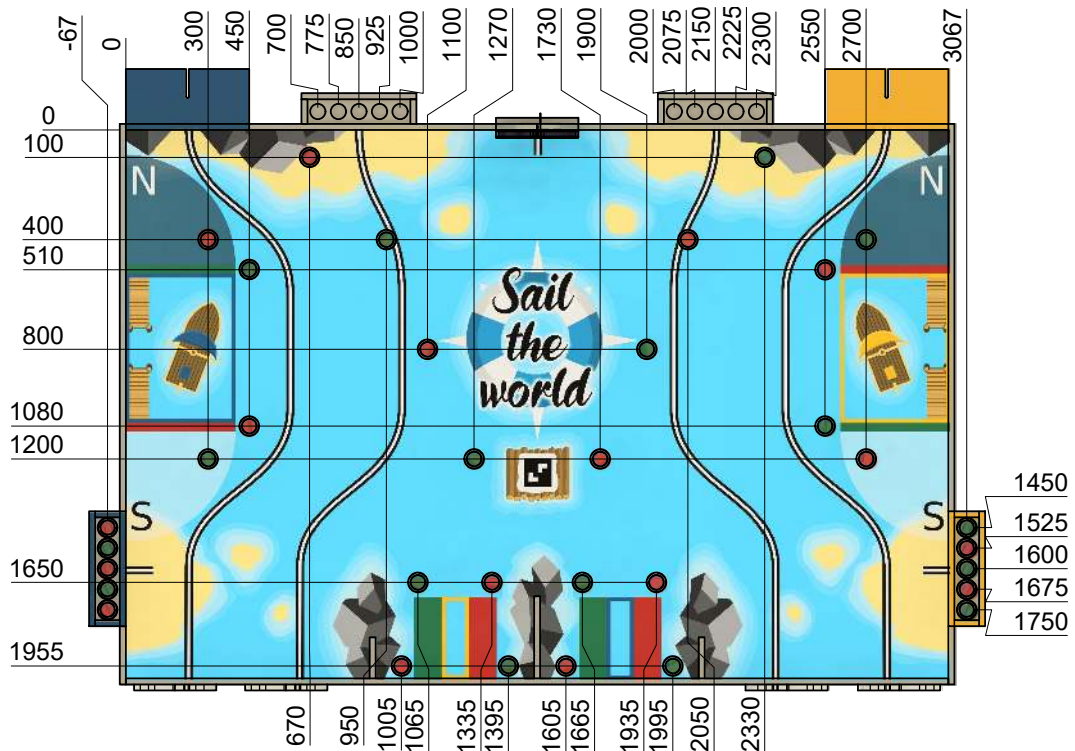

Figure 16 – Top view of the playing area with the fixed buoys at their initial positions

I.1.a. BUOYS

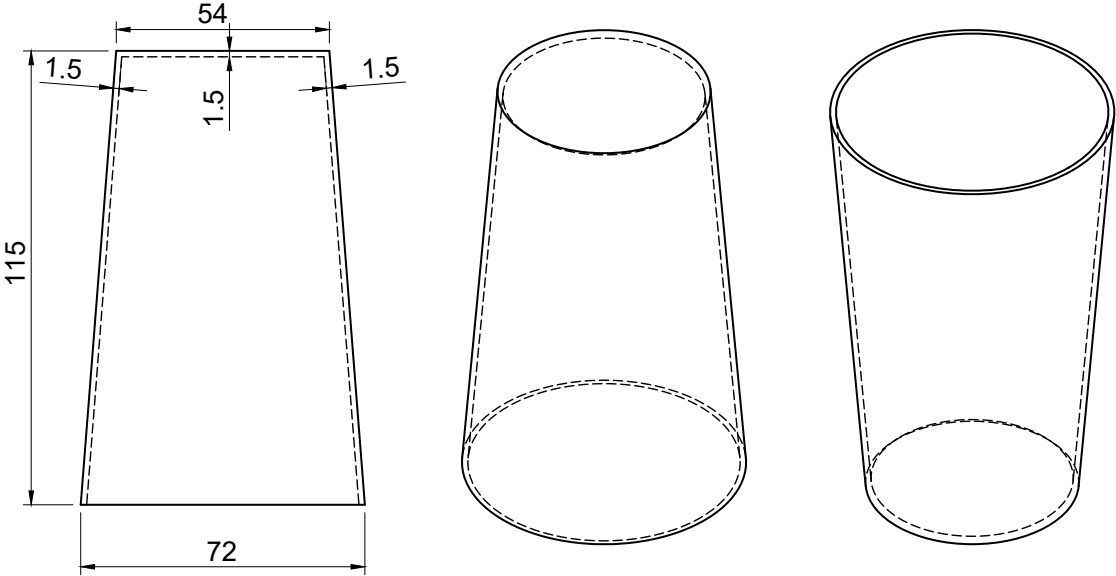

Figure 17 – Buoy

I.1.b. ROCKY AREA AND LIGHTHOUSE

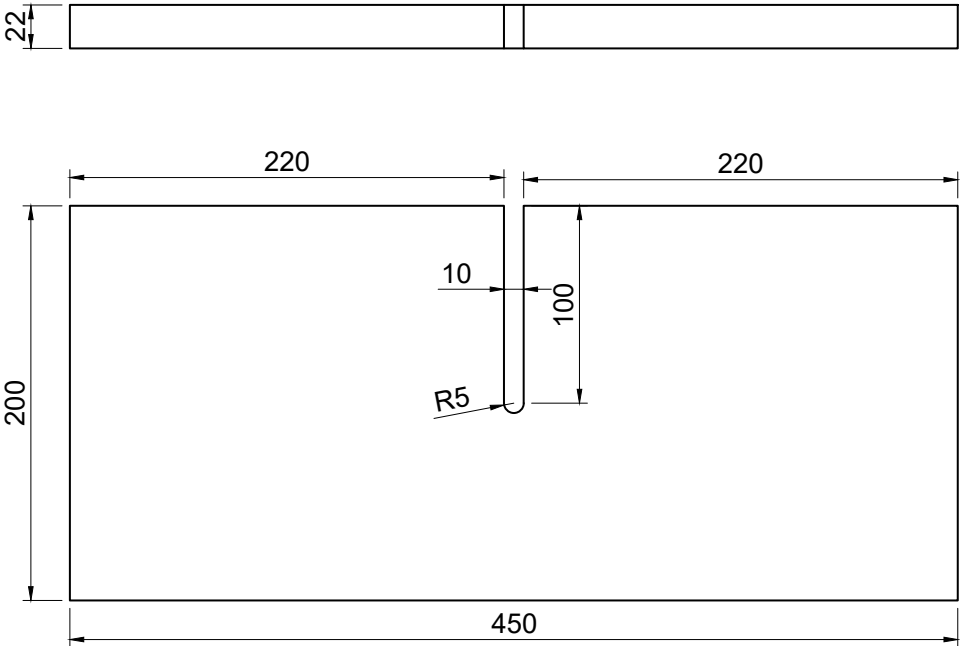

Figure 18 – Rocky area

I.1.c. WEATHERVANE

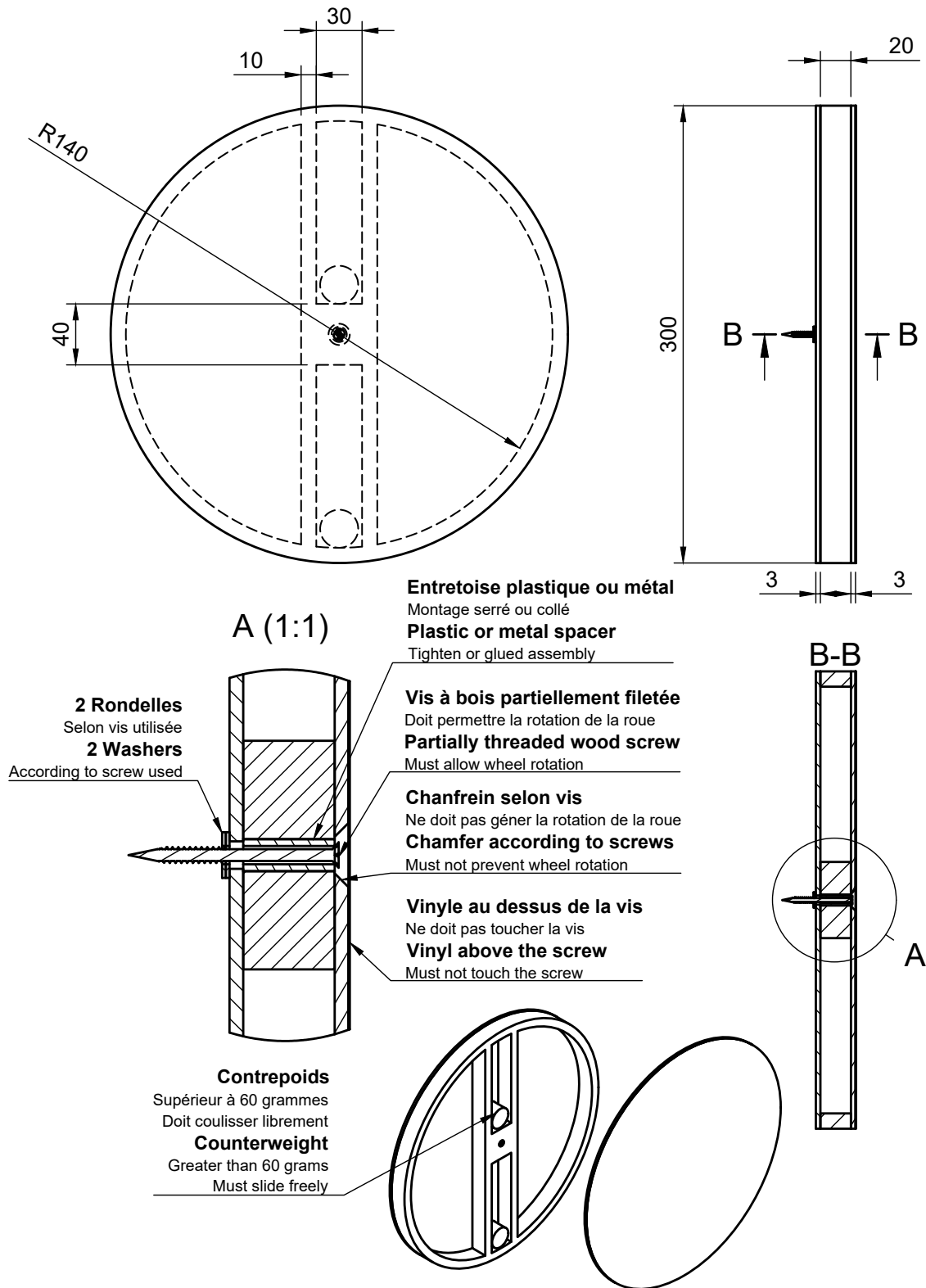

Figure 19 – Weathervane

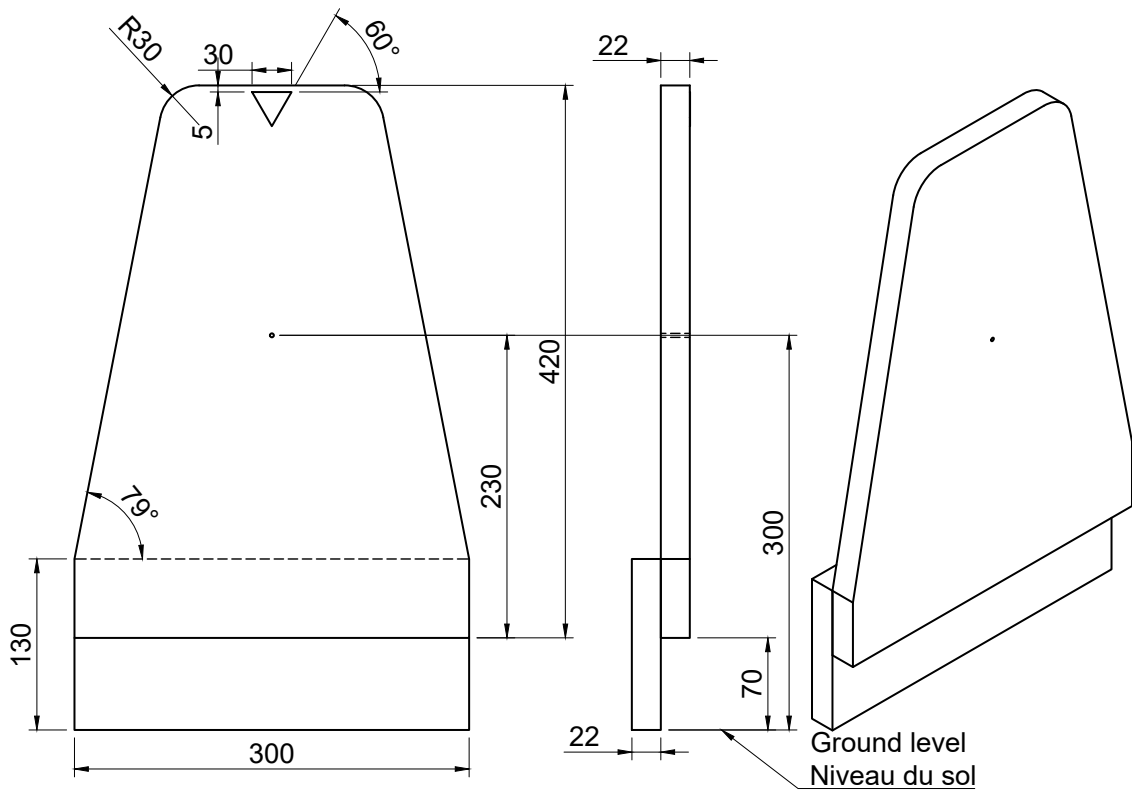

Figure 20 – Weathervane support

I.1.d. GROUNDED ZONES

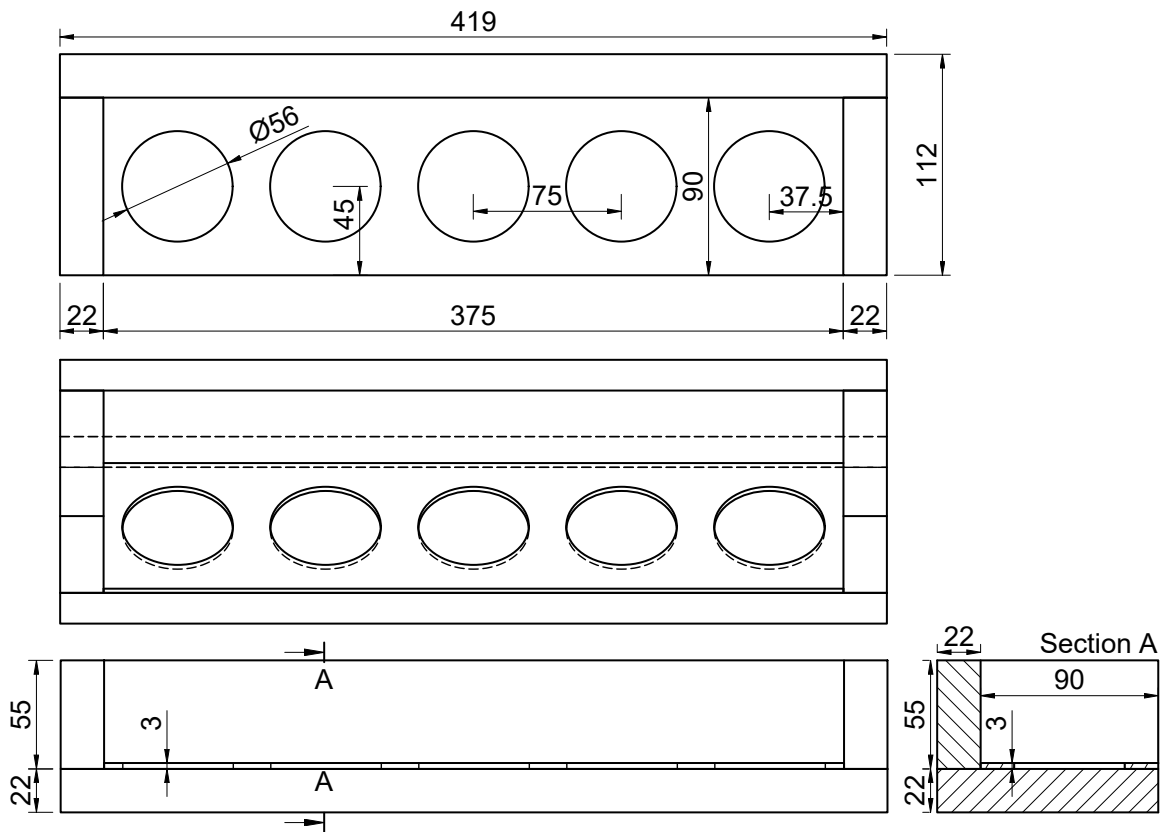

Figure 21 – Grounded Zone

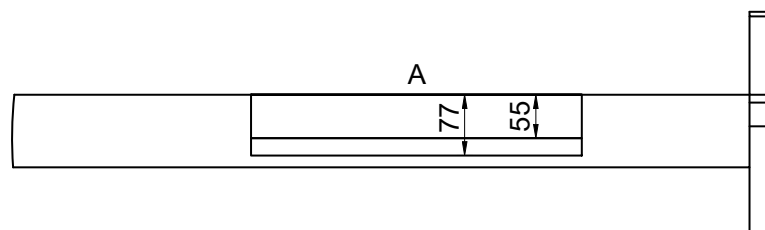
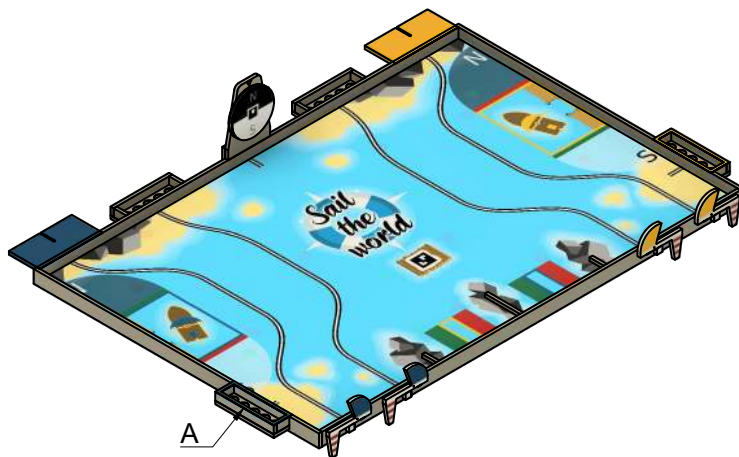

Figure 22 – Grounded Zone height

I.1.e. WINDSOCKS

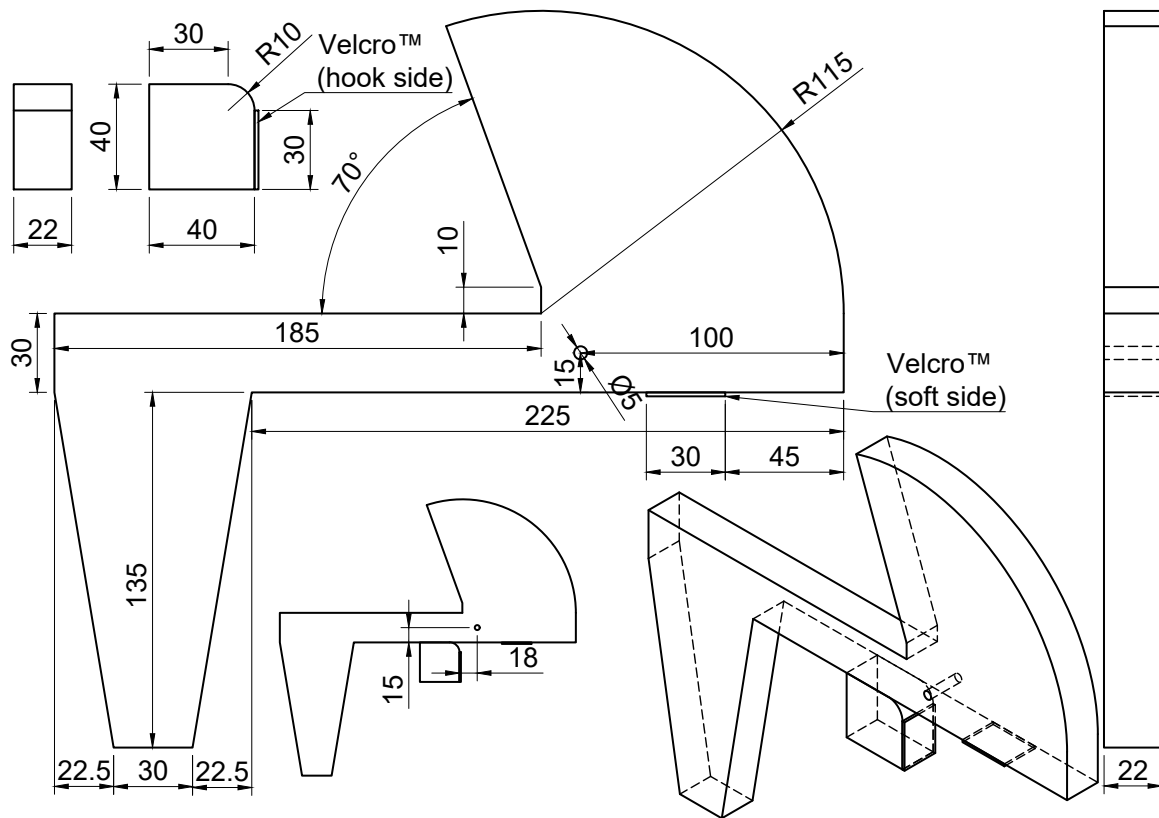

Figure 23 – Windssock

Notice: all the faces are covered by a vinyl whereas the slices are painted in white.



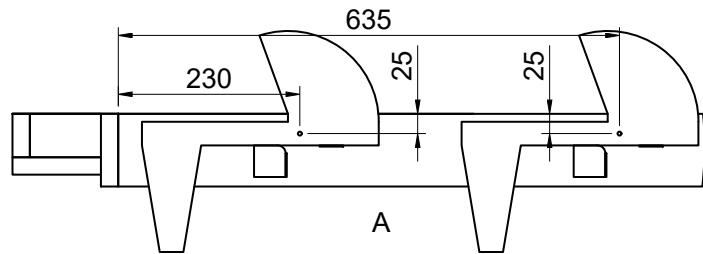
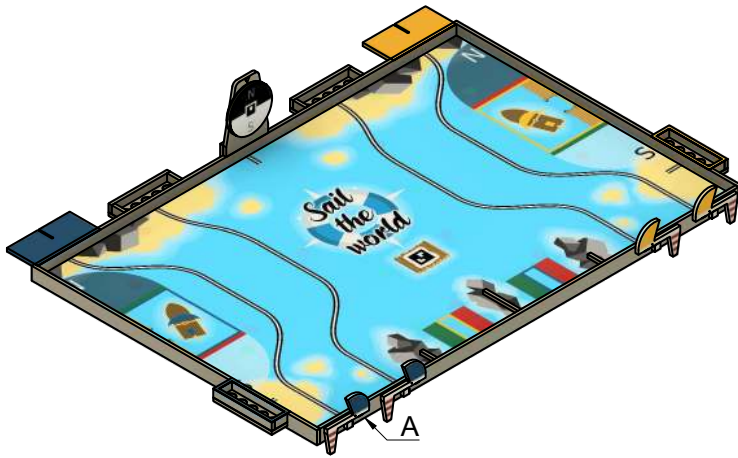

Figure 24 – Windsock height

I.1.f. PORT PROTECTION CLEATS

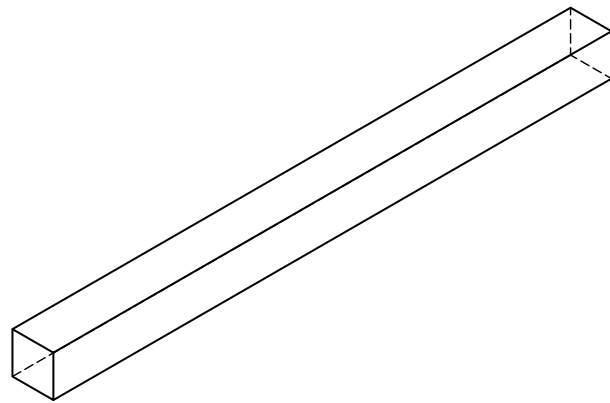
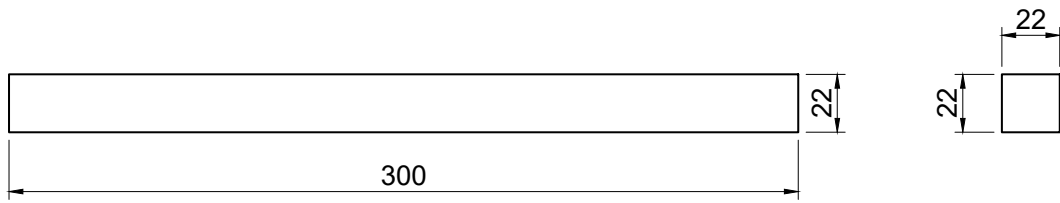

Figure 25 – Central cleat

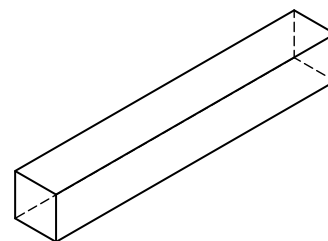
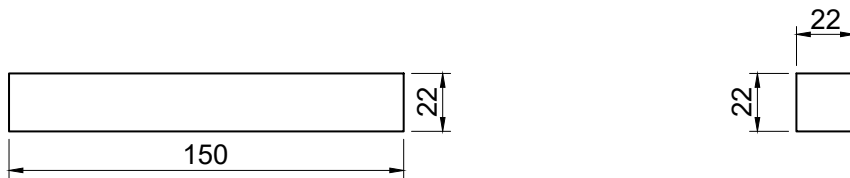

Figure 26 – Side cleat

## I.2. MATERIAL REFERENCES

Elements	Material or reference	Comments
Buoys	Plastic	Blank reusable cup 25cl/33cl atelier-dugobelet.fr, dark green ("vert foncé") and red ("rouge"). <sup>1</sup>
Game floor	Printed monomeric gripping vinyl	Ordering information will be provided by Planète Sciences
Weathervane	Wood - Steel - Plexiglas	
Rocky area	Wood	
Central separators	Wood	
Grounded zones	Wood	
Windsocks	Wood - Velcro <sup>TM</sup> - Vinyl	
Robot identification marker	Polystyrene - Plastic - Vinyl - Velcro <sup>TM</sup>	

## I.3. MANUFACTURING TOLERANCES

All dimensions are in millimeters (or mm). Manufacturing tolerances shall comply with the following rules, unless otherwise specified directly on the drawings.

Dimensions	General Tolerances
$\leq 20$	$\pm 1.50$
$> 20$ and $\leq 70$	$\pm 2.50$
$> 70$ and $\leq 150$	$\pm 4.00$
$> 150$	$\pm 5.00$

**No objections regarding differences in dimensions will be taken into account.**

The material's density can change from one country to another. It is highly recommended that the teams try different types of wood since the weight may differ significantly.

<sup>1</sup>Cups & mugs > Reusable cups 25cl/33cl > Blank cup 25cl/33cl. Possible mix ("panachage") : <http://www.atelierdugobelet.fr/en/gobelets-25cl/622-gobelet-vierge-25cl.html>. In case of supply difficulties, contact your National Organizing Committee (NOC) to find out if they are doing a group order.

#### I.4. COLOUR REFERENCES

	Colors	References	CMYK
Team blue	Traffic blue	RAL 5017 Mat	100% , 60% , 0% , 10%
Team yellow	Traffic yellow	RAL 1023 Mat	0% , 25% , 100% , 0%
Buoys and fairways	Mint green	RAL 6029 Mat	100% , 5% , 90% , 30%
Buoys, fairways and windsocks	Traffic red	RAL 3020 Mat	0% , 100% , 100% , 10%
Borders and non-colored elements	Pebble grey	RAL 7032 Mat	15% , 10% , 25% , 20%
Windsocks	White	RAL 9010 Mat	0% , 0% , 5% , 0%

**RAL hues can vary from a printed soil mat to another.**

## I.5. MARITIME SIGNAL FLAGS

All maritime flags must be taken from the International maritime signal flags. They are reproduced below. The dimensions and ratios can be freely chosen as long as the constraints in section D.8. are satisfied. Further notice: number flags are never used in 2-flags codes; that's why they are not included here. Nevertheless, they can be used when the hoisted codes have already two letters (and so with at least three flags).

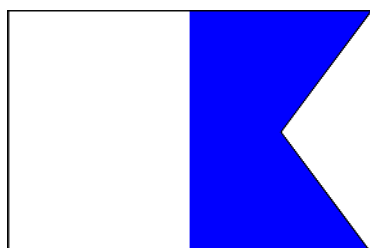

A - Alpha

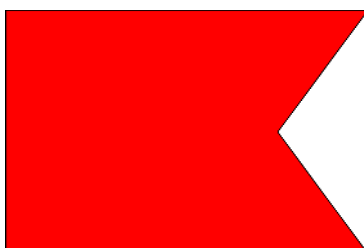

B - Bravo

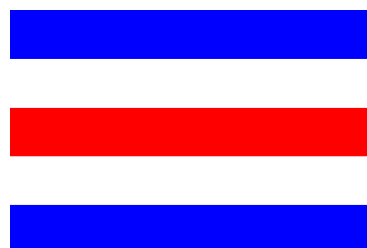

C - Charlie

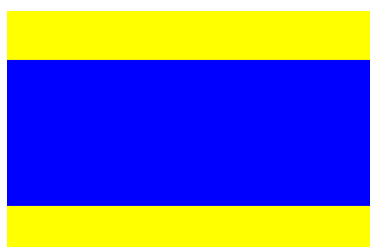

D - Delta



E - Echo

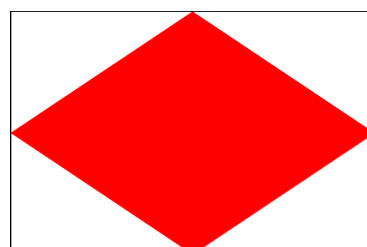

F - Fox-Trot

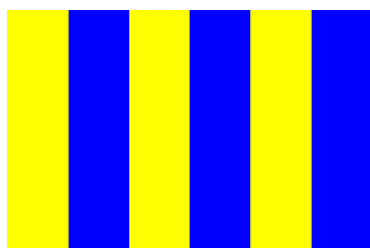

G - Golf



H - Hotel

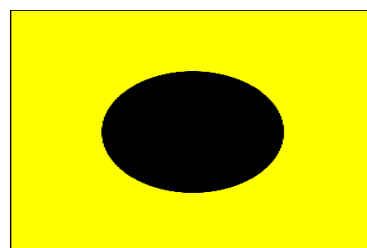

I - India



J - Juliett

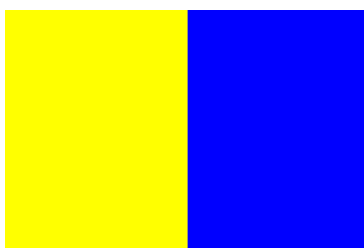

K - Kilo

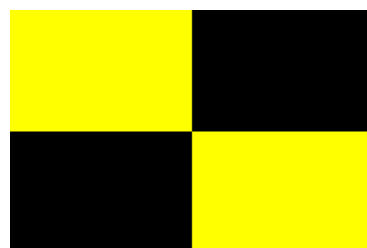

L - Lima

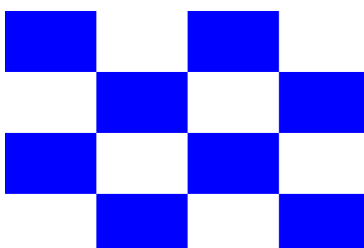

M - Mike

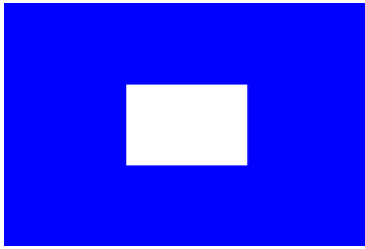

N - November

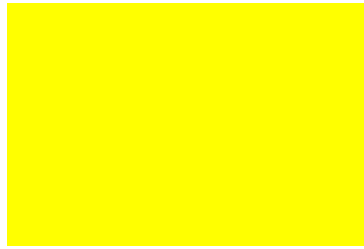

O - Oscar

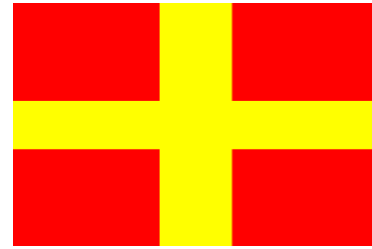

P - Papa

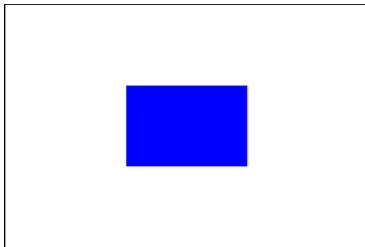

Q - Quebec

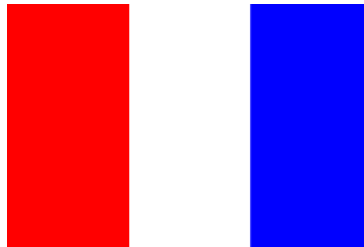

R - Romeo

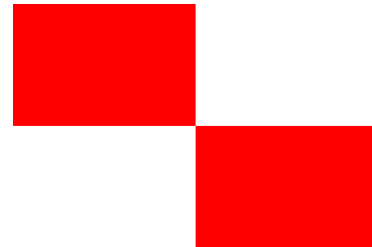

S - Sierra

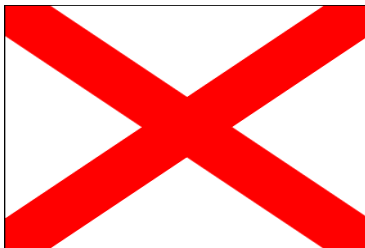

T - Tango

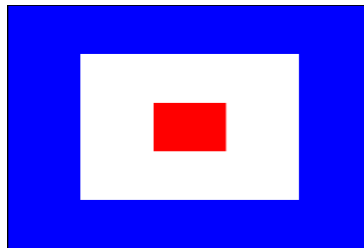

U - Uniform

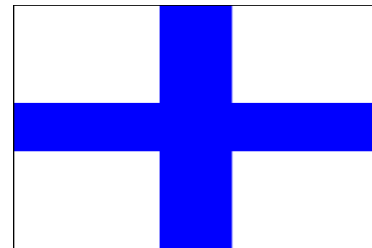

V - Victor



W - Whisky



X - X-Ray

Y - Yankee

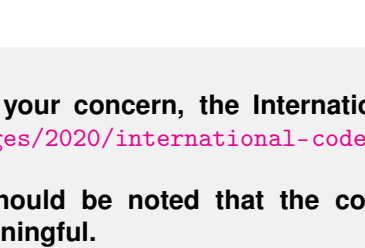

Z - Zulu

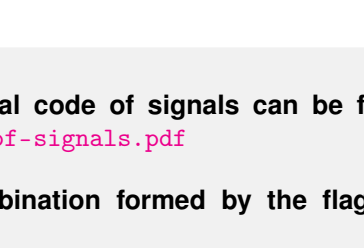

For your concern, the International code of signals can be found on: <https://www.eurobot.org/images/2020/international-code-of-signals.pdf>

It should be noted that the combination formed by the flags does not necessarily have to be meaningful.