

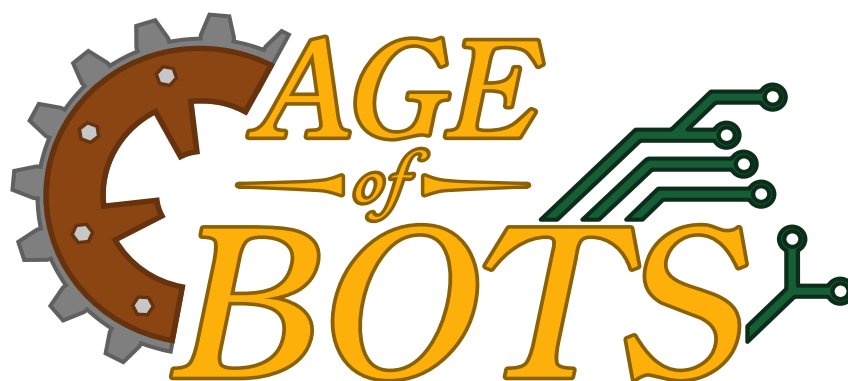

Eurobot^{Open} Junior 2022 Rules

29th edition of the robotic contest - Eurobot
OFFICIAL version



NOTE: all images in this document are provided as a guide to illustrate the various paragraphs. In no case they can serve as a reference. Only the dimensions, colors and materials indicated in the appendix shall be taken into consideration.

A. NOTICE	4
B. CONTEST PRESENTATION	5
C. THEME PRESENTATION	7
D. PLAYING AREA AND ACTIONS	8
D.1. IMPORTANT INFORMATION	8
D.2. PLAYING AREA	9
D.3. STARTING AREAS	10
D.3.a. DESCRIPTION	10
D.3.b. CONSTRAINTS	10
D.4. DESCRIPTION AND LAYOUT OF THE PLAYING ELEMENTS	11
D.5. FINDING THE EXCAVATION SQUARE	15
D.5.a. DESCRIPTION AND LAYOUT OF THE PLAYING ELEMENTS	15
D.5.b. ACTIONS AND CONSTRAINTS	15
D.5.c. POINTS	15
D.6. RESEARCH AND ANALYSIS OF SAMPLES AT THE CAMPSITE	16
D.6.a. DESCRIPTION AND LAYOUT OF THE PLAYING ELEMENTS	16
D.6.b. ACTIONS AND CONSTRAINTS	16
D.6.c. POINTS	16
D.7. EXHIBITION GALLERY	17
D.7.a. DESCRIPTION AND LAYOUT OF THE PLAYING ELEMENTS	17
D.7.b. ACTIONS AND CONSTRAINTS	17
D.7.c. POINTS	17
D.8. STORING SAMPLES IN THE WORK SHED	18
D.8.a. DESCRIPTION AND LAYOUT OF THE PLAYING ELEMENTS	18
D.8.b. ACTIONS AND CONSTRAINTS	18
D.8.c. POINTS	18
D.9. TO PRESERVE AND EXHIBIT THE STATUETTE	19
D.9.a. DESCRIPTION AND LAYOUT OF THE PLAYING ELEMENTS	19
D.9.b. ACTIONS AND CONSTRAINTS	19
D.9.c. POINTS	20
D.10.DISPLAY CABINET	21
D.10.a.DESCRPTION AND LAYOUT OF THE PLAYING ELEMENTS	21
D.10.b.ACTIONS AND CONSTRAINTS	21
D.10.c.POINTS	21
D.11.RETURN TO THE EXCAVATION SITE OR THE CAMP	22
D.11.a.DESCRPTION AND LAYOUT OF THE PLAYING ELEMENTS	22
D.11.b.ACTIONS AND CONSTRAINTS	22
D.11.c.POINTS	22
D.12.ESTIMATE THE PERFORMANCE	23
D.12.a.DESCRPTION AND LAYOUT OF THE PLAYING ELEMENTS	23
D.12.b.ACTIONS AND CONSTRAINTS	23
D.12.c.POINTS	23
E. PROJECT PRESENTATION	24
E.1. CONSTRAINTS	24
E.2. EVALUATION	24

F. THE ROBOTS	25
F.1. FOREWORDS	25
F.2. DIMENSIONS	26
F.3. ENERGY SOURCES	27
F.4. OTHER DESIGN CONSTRAINTS	27
F.4.a. THE WIRE CONTROL SYSTEM	28
F.4.b. THE WIRELESS CONTROL SYSTEM	28
F.4.c. THE CABLE	29
F.4.d. THE CONTROL SYSTEM FOR THE AUTONOMOUS SECONDARY ROBOT	29
F.5. SECURITY CONSTRAINTS	29
F.5.a. GENERAL ASPECTS	29
F.5.b. LASERS	30
F.5.c. HIGH POWER LIGHT SOURCES	30
F.5.d. COMPRESSED AIR SYSTEMS	30
G. MATCHES	31
G.1. PREPARATION TIME	31
G.2. THE MATCH	31
G.3. COUNTING POINTS	32
G.3.a. FINDING EXCAVATION SQUARE	32
G.3.b. RESEARCH AND ANALYSIS OF SAMPLES AT THE CAMPSITE	32
G.3.c. STORING SAMPLES IN THE WORK SHED	32
G.3.d. RETURN TO THE EXCAVATION SITE OR THE CAMP	32
G.3.e. TO PRESERVE AND EXHIBIT THE STATUETTE	32
G.3.f. DISPLAY CABINET	32
G.3.g. ESTIMATE THE PERFORMANCE (BONUS POINTS)	33
G.3.h. THE PENALTIES	33
G.3.i. BONUS POINTS	33
G.3.j. FORFEIT CASES	33
H. THE CONTESTS	34
H.1. GENERAL INFORMATION	34
H.2. APPROVAL	34
H.2.a. STATIC APPROVAL	34
H.2.b. DYNAMIC APPROVAL	34
H.2.c. SIGNIFICANT TECHNICAL MODIFICATIONS AFTER THE APPROVAL	34
H.3. QUALIFICATION PHASE	34
H.4. THE PLAY-OFF PHASE	35
H.5. THE FINAL PHASE	36
H.6. QUALIFICATION FOR THE NATIONAL MEETING	36
H.7. QUALIFICATION FOR THE EUROPEAN MEETING	36
I. APPENDIX	38
I.1. GENERAL DRAWINGS	38
I.1.a. SAMPLE	40
I.1.b. EXHIBITION GALLERY	41
I.1.c. SAMPLE SUPPORT	42
I.1.d. DISPLAY CABINET	43
I.1.e. STATUETTE SUPPORT	44
I.1.f. EXCAVATION SQUARE	45
I.1.g. GALLERY SPLIT CLEATS	46
I.2. MATERIAL REFERENCES	47
I.3. MANUFACTURING TOLERANCES	47

I.4. COLOUR REFERENCES 48

A. NOTICE

WARNING!

General remarks are annotated in the document. Please, pay special attention to these points.

This year the rules have been split up. Most parts remain the same for the Eurobot^{Open} and Eurobot^{Open} Junior contests, but to avoid confusion, each contest has its own rules as a single document.

Thus the particular cases specific to one of the competitions appear only in the document concerning it.

You will find the Eurobot^{Open} and the Eurobot^{Open} Junior rules and other information on the Eurobot^{Open} website (<http://www.eurobot.org/>)

Please note that the version of this release is noted down at the end of this page. For any inquiry, only an official version should be considered.

Changes or clarifications of the rules may be made during the year. We therefore strongly encourage all participants to check our website regularly (<http://www.eurobot.org/>) as well as your NOC's own website for news. You can also follow discussions, ask questions or get further assistance on our forum (<http://www.planete-sciences.org/forums/>).

Possible changes of the technical specifications will be announced on the Eurobot website, (<http://www.eurobot.org/>) or on the website of the National Organization Committee (NOC) in your country.

The forum responses from a referee are official responses taken into account for match refereeing and homologation stages.

In case of doubt regarding any point of the rules or the approval of robots, the referee committee may also be contacted at referee@planete-sciences.org.

Have a good reading!

B. CONTEST PRESENTATION

Eurobot^{Open} and Eurobot^{Open} Junior are two events addressed to young people interested in robotics. Teams are usually composed of students involved in an Eurobot^{Open} school project, a group of friends, or independent robotics clubs. They share the same goal: to offer young people an active learning process, to put into practice their knowledge and soft skills during a fun and friendly event.

The rules for both events (Eurobot^{Open} and Eurobot^{Open} Junior) are based on the same concept. As organisers, we intend to provide a common platform for the Eurobot^{Open} event. This platform is dedicated to autonomous robots for Eurobot^{Open} while for Eurobot^{Open} Junior, the robots are remote controlled. In this way, a Eurobot^{Open} organiser can easily set up a Eurobot^{Open} Junior contest and vice versa. Remember this when you will be organizing your official or unofficial event.

You're currently reading version
Eurobot^{Open} Junior OFFICIAL
of 2022rules
(this version concerns only the wire-guided robots)

Participants in the Eurobot^{Open} Junior finals must be aged up to 18 years. Each team must have a supervisor to whom the age limit does not apply.

The technical challenge is to build a remote controlled robot as well as an optional autonomous robot.

Be careful, depending on your country's educational system, this age limit may be slightly different. Check the registration requirements stated by your National Organizing Committee.

A team is a group of young people who have built one or two robots for the event. A person can only represent one team. However, we encourage teams to share their expertise and knowledge.

An organization (club, school, etc.) can supervise and register several teams, if allowed by the registration requirements set by your National Organizing Committee. The acceptance of these requirements is compulsory to validate your registration and your entry.

The project can be supervised by someone over the age limit (teacher, parent, group leader, etc.), but all elements of the robot(s) must be designed by the participants. In this context, robots manufactured from a commercially purchased chassis or rolling base will not be accepted.

In the event that a robot was imagined, built or modified by the tutor alone, organisers can disqualify or reject the participation of the team in the competition. Students must be capable of describing and explaining the manufacturing process of their robots. It is strictly forbidden that the tutor modifies the robot during the competition. He can in exchange advise the students and guide them.

The objective of the secondary robot is to allow young people to experiment with programming. It is tolerated to use a commercial robotic base for this robot unlike the main robot. As the work is mainly on programming, it will be asked during the event that the students present the program and are able to explain it to the referees.

Eurobot^{Open} and Eurobot^{Open} Junior must take place in a friendly, fair-play spirit. As for every sport event, referees' decisions are pronounced without a possible recourse, except if an agreement between all stakeholders is met.

Eurobot^{Open} and Eurobot^{Open} Junior European finals gather teams selected after national qualifications. European finals take place in Europe, but all countries can participate. Countries where more than three teams are registered have to organize a national qualification to select teams that will attend the European finals.

Common parameters can change from one year to another. Accordingly, please read the rules carefully even if the chapters may seem familiar to you (playing area dimensions, robots dimensions, starting area dimensions etc.).

Robotics contests are public events. Therefore, we ask the teams to respect our rules of decency and safety (electrical, sound level, manners, etc.). These rules apply to the participants, their supporters and all the equipment they bring.

C. THEME PRESENTATION

After many years of exploring the world and the universe, our friends - the robots - have decided to explore their past. In 2022, the robots will go to search the ruins of an ancient robotic civilization for the forgotten fragments of their origin.

Our experienced archaeologists are expecting excavation squares, hidden treasures and sacred statues and nothing will stop them from recovering their past. .

So get out the shovels and pickaxes, because adventure is waiting for us!

Our missions will be:

- **Discovering the excavation square.**
- **Researching and analysing samples.**
- **Storing samples in the work shed.**
- **Proudly displaying your discoveries in the museum.**
- **Preserving and exhibiting the statuette.**
- **Returning to the campsite**, at the end of the day.
- **Estimating your performance.**

Warning! All actions are independent from one another and no specific sequence is imposed whatsoever. No single action is compulsory. Give careful thoughts to your strategy. It is strongly recommended to design simple and reliable systems with a limited number of actions.



Figure 1 – Overview of the playing area

D. PLAYING AREA AND ACTIONS

D.1. IMPORTANT INFORMATION

The organisers are committed to building the playing area with as much accuracy as possible. Nevertheless, they reserve the right to do minor modifications and adjustments.

No complaints regarding dimensional deviations will be taken into account.

Teams are warned that the surface condition may differ from one playing area to another and may also degrade over time.

Graphics displayed in this document represents the Eurobot^{Open} playing area and not the Eurobot^{Open} Junior one. Thus figures show elements not useful in this version of the rules such as fixed beacon supports and central tracking device.

D.2. PLAYING AREA

The playing area is a horizontal rectangular plan of 3000 mm by 2000 mm with borders of 70 mm height on each side. Depending on the building process, it may consist of one or more pieces (eg 3 pieces of 1000 mm per 2000 mm).

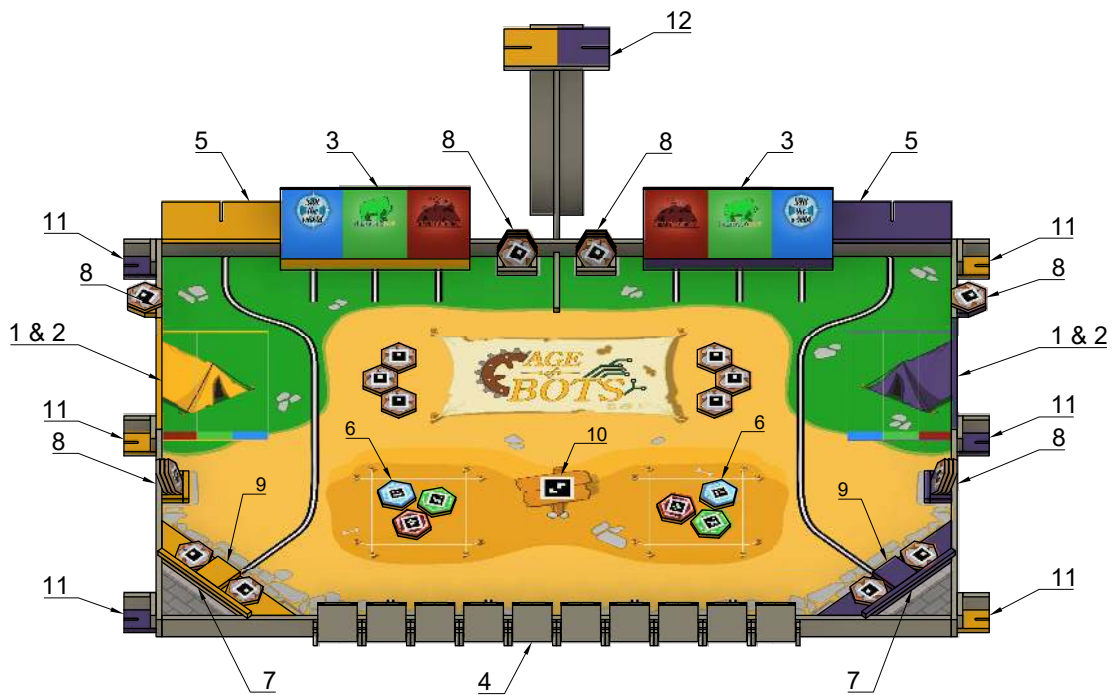

Figure 2 – Detailed view of the playing area

- | | |
|-----------------------|---------------------------------------|
| 1. Starting areas | 7. Work shed |
| 2. Campsite | 8. Dispensers |
| 3. Gallery | 9. Pedestal |
| 4. Excavation squares | 10. ArUco marker number 42 |
| 5. Exhibition hall | 11. Fixed beacon supports (Eurobot) |
| 6. Excavation site | 12. Central tracking device (Eurobot) |

Full specifications of the playing area and game elements (dimensions, positions at the beginning of the match, colors and other references) are listed in the appendix.

In the remainder of this document, horizontal and vertical directions are stated relative to the playing area. Notions of “left”, “right”, “front” and “back” are stated with respect to the spectator’s point of view, located on excavation squares side.

D.3. STARTING AREAS

D.3.a. DESCRIPTION

Each team has a starting area for their robots. It is a rectangular surface delimited by a border of the team's color (the border is included in this zone).



(a) yellow starting area



(b) purple starting area

D.3.b. CONSTRAINTS

At the end of the setup time, the vertical projection of the robots must not exceed the limits of the starting area.

Make sure your robots can fully enter the starting area. Overtaking above the lateral border but not beyond the playing area is allowed.

The starting area does include the color lines.

Robots are not allowed to enter the starting area of the opposing team during the entire match.

D.4. DESCRIPTION AND LAYOUT OF THE PLAYING ELEMENTS

Samples : The samples are solid hexagons with 150 mm of outer diameter, 15 mm of thickness and a maximal weight of 150 g. A sample got two faces: a treasure face, and a rock face. There are 30 samples on the table, and they are initially placed on predefined positions (each time with one of each color):

- 3 on the surface of the playing area in front of the starting areas; they are positioned with the "rock" side facing up, and enable for both teams.
- 3 on the surface of the playing area inside the excavation site; they are positioned with the "treasure" side facing up, and enable for both teams.
- 1 in the horizontal dispenser placed on the lateral side close to the campsite, and reserved for one team according to its color.
- 2 in the horizontal dispensers placed close to the Statuette (genuine), included on the work shed, and reserved for one team according to its color.
- 3 in the vertical dispensers placed beside the galleries, and enable for both teams.
- 3 in the vertical dispensers placed beside the campsite and reserved for one team according to its color.
- The order of the samples in horizontal dispensers is defined once for all : red one is touching the border, green one is the intermediary sample and blue one is located on the playing side.

ArUco 4x4 tags are printed at the center of the hexagonal faces of the samples in the following way:

- Tag number **47** on the **treasure** face of the **red** samples.
- Tag number **13** on the **treasure** face of the **blue** samples.
- Tag number **36** on the **treasure** face of the **green** samples.
- Tag number **17** on the **rock** face of **all samples**.

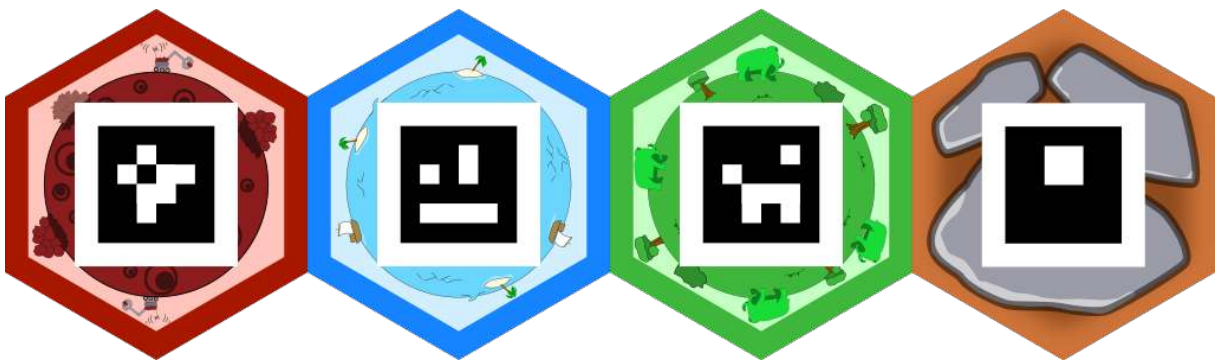
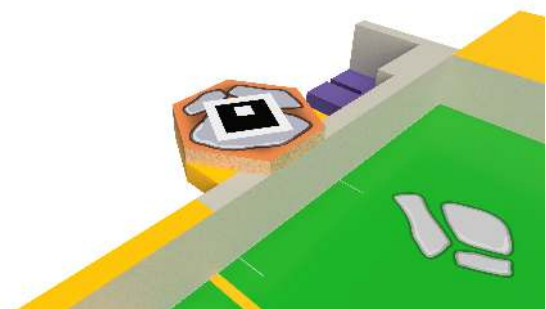

Figure 4 – The 3 face "treasure", and the face rock



(a) Dispensers



(b) Dispensers

Campsites: These are the colored zones for each team located along the lateral side of the playing area, and split in 3 colored area, one for each historical period. The campsites are the start zone of each team.

Work shed: The work shed is the area under the statuette support, forming a triangle delimited by a red line and by the closest table corner. Each teams work shed is located on the same side as their starting area.

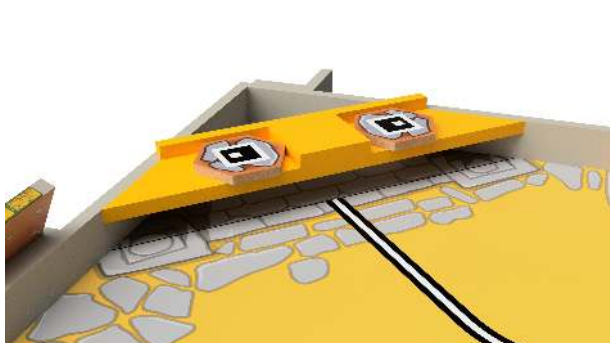

(a) Work Shed and Pedestal (inner view)

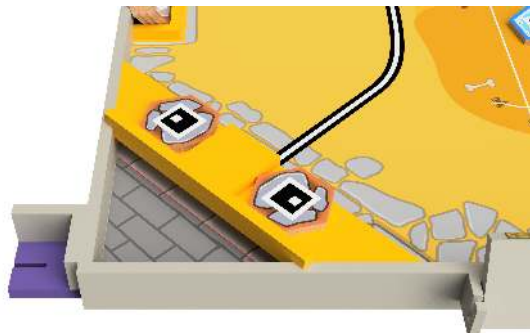

(b) Work Shed and Pedestal (outter view)

Excavation site: The excavation site is shared by the two teams and the samples are randomly scattered inside.



Figure 7 – Excavation site

The galleries: The gallery is the support at 60° placed on the front of the table and split in 3 colored area, one for each historical period, and located near the display cabinet. Each team has its own gallery on its table side.



(a) Gallery yellow



(b) Gallery purple

Excavation square: The excavation square are solid square placed on the front side of the table, and must be toggle by the robots. The excavation square are distinguished by a marker on the upper side, and by a vinyl of each face.

On inner face, a vinyl is placed with the team's color and its treasure, or a red cross.



Figure 9 – Excavation square

The excavation square can be placed according to the configuration:



Figure 10 – Excavation square possible configurations

Markers: Located on the top side of the excavation square, the markers are PCB linking the excavation square to a team according to the resistance which can be measured across their surface.

The markers with a resistance of 470 Ohm are associated with the team purple .

The markers with a resistance of 1 kOhm are associated with the team yellow .

The markers with a resistance of 4,7 kOhm are not associated with any team. They must not be flipped.

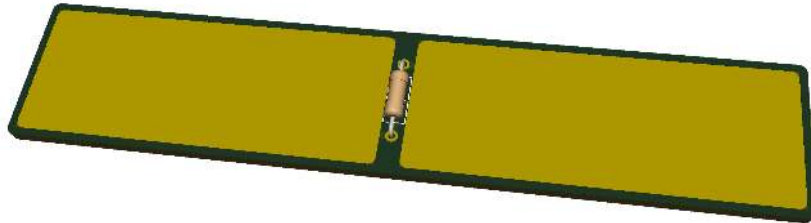

Figure 11 – marker

Statuette (genuine): Made by the team, the statuette is an element placed on the pedestal of the team before the match.

Replica (of the statuette) : Provided by the organisation, the replica is an element pre-loaded in a team's robot or placed in the display cabinet before the match.

Pedestal: Support of the statuette, in the colour of each team, positioned at the center of the diagonal beam above the work shed.

Exhibition hall: The horizontal surface of the exhibition hall is at the level of the top of the playing area border, located at the back of the table, on the same side of the starting area of the team.

Display cabinet: Made by the teams, the display cabinet is the place to deposit the statuette after the swap. It must be fixed on the exhibition hall before the match.

D.5. FINDING THE EXCAVATION SQUARE

During their researches, robots can have some surprises! After their arrival on the site, they must detect the most promising squares before revealing their treasures. And be careful not to be too greedy, at the risk of having unpleasant surprises.

D.5.a. DESCRIPTION AND LAYOUT OF THE PLAYING ELEMENTS

For this action, only the excavation squares are used.

D.5.b. ACTIONS AND CONSTRAINTS

Actions:

- Robots have to identify the excavation squares associated to their team, and flip them.

Constraints:

- The square already flipped can not be raised.
- An excavation square is considered as flipped when its marker is under the playground level.
- The reveal of a team's red square invalidate all the team's excavation squares.
- Robots are not allowed to lift the excavation square: they must remain in contact with their support at all times during the match.
- The square are split in 3 sections:
 - 3 squares on right reserved to the team purple
 - 3 squares on left reserved to the team yellow
 - 4 central squares for both teamsThe robot are not allowed to use the squares of the other team.

D.5.c. POINTS

- **5 points** for each revealed excavation square at the team's colour;
- **5 points additional** if a least a excavation square at the team's colour is revealed, and the red square at the team's side is not revealed;

D.6. RESEARCH AND ANALYSIS OF SAMPLES AT THE CAMPSITE

The archaeology-robots set out on a mission to reveal buried riches. Once they have brought their discoveries to light, they will be able to analyse them.

D.6.a. DESCRIPTION AND LAYOUT OF THE PLAYING ELEMENTS

The samples and campsites are used for this action.

D.6.b. ACTIONS AND CONSTRAINTS

Actions:

- Collect the samples to bring them to the campsite
- Sort the samples inside the campsite, in function of the color of the treasure side of the sample and the color of the campsite zone.

Constraints:

- To be considered as valid on the campsite, a sample must be in the vertical projection of the campsite surface, regardless of its position.
- A sample is considered as sorted over its historical period if it is facing "treasure" side up (the colors of the area and the treasure side must be the same) and at least three of its corners are included in the vertical projection of the corresponding period.
- Each campsite is assigned to a team. They are not accessible to the opposite team, which must not under any circumstances move the samples that are already placed there.
- If a sample is still under a robot's control at the end of the match, it will not be counted.
- A sample is considered out from the dispenser when it's vertical projection is not intersecting the vertical projection of the dispenser.

D.6.c. POINTS

- **1 point** for each sample removed from a distributor on the team side (including the shared distributor and the work shed);
- **1 point** for each sample inside the camp;
- **1 additional point** for each revealed and sorted sample inside the camp;

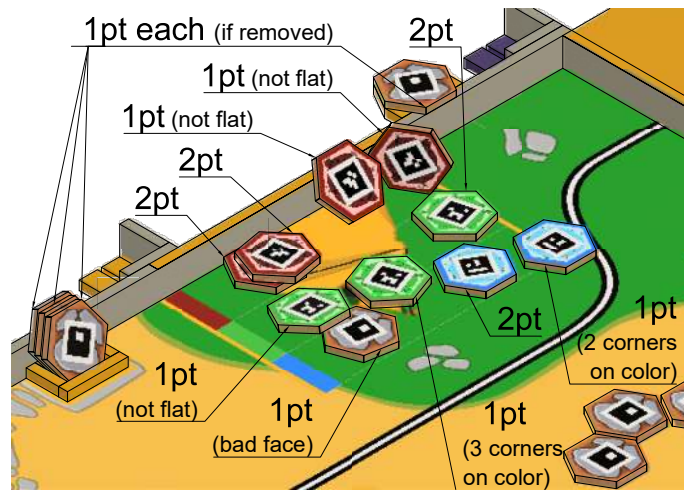

Figure 12 – Sample's validity within the camp

D.7. EXHIBITION GALLERY

In a museum with a large gallery, the archaeology-robots will have the task of exhibiting the most beautiful samples.

D.7.a. DESCRIPTION AND LAYOUT OF THE PLAYING ELEMENTS

For this action, the robots will interact with the samples and the gallery.

D.7.b. ACTIONS AND CONSTRAINTS

Actions:

- Collect the samples to place them on the gallery.
- Sort the samples in the gallery.

Constraints:

- For a sample to be considered valid on the gallery, it must be in contact with the surface of one of the historical periods.
- A sample is considered as sorted on its period if its "treasure" side is facing the public (the colors of the area and the treasure side must be the same) and at least three of its corner are touching the period.
- Each gallery is assigned to a team. They are not accessible to the opposite team, which must not under any circumstances move the samples that are already placed there.
- If a sample is still under a robot's control at the end of the match, it will not be counted.
- Only 9 samples will be scored, starting with the ones with the lower score greater to 0.

D.7.c. POINTS

- **3 points** for each sample inside the gallery;
- **3 additional points** for each revealed and sorted sample inside the gallery;

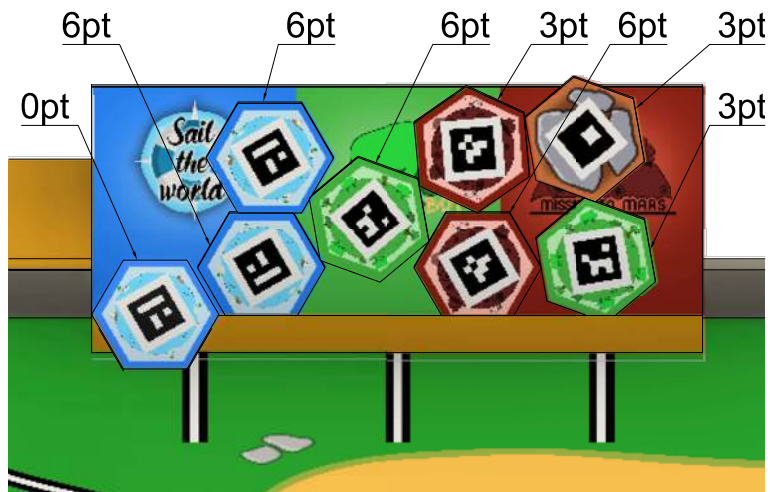

Figure 13 – Sample's validity within the gallery

D.8. STORING SAMPLES IN THE WORK SHED

D.8.a. DESCRIPTION AND LAYOUT OF THE PLAYING ELEMENTS

For this action, the robots will interact with samples and the work shed.

D.8.b. ACTIONS AND CONSTRAINTS

Actions:

- Send/drop the samples in the work shed

Constraints:

- For a sample to be considered as valid in the work shed, at least 3 of the corners of one of its hexagonal faces must be in contact with the surface of the playground, and in the triangle constituting the work shed, delimited by the field borders and the red line.
- If a sample is still under a robot's control at the end of the match, it will not be counted.
- Each work shed is assigned to a team. They are not accessible to the opposite team, which must not under any circumstances move the samples that are already placed there.

D.8.c. POINTS

- **5 points** for each sample inside the work shed;

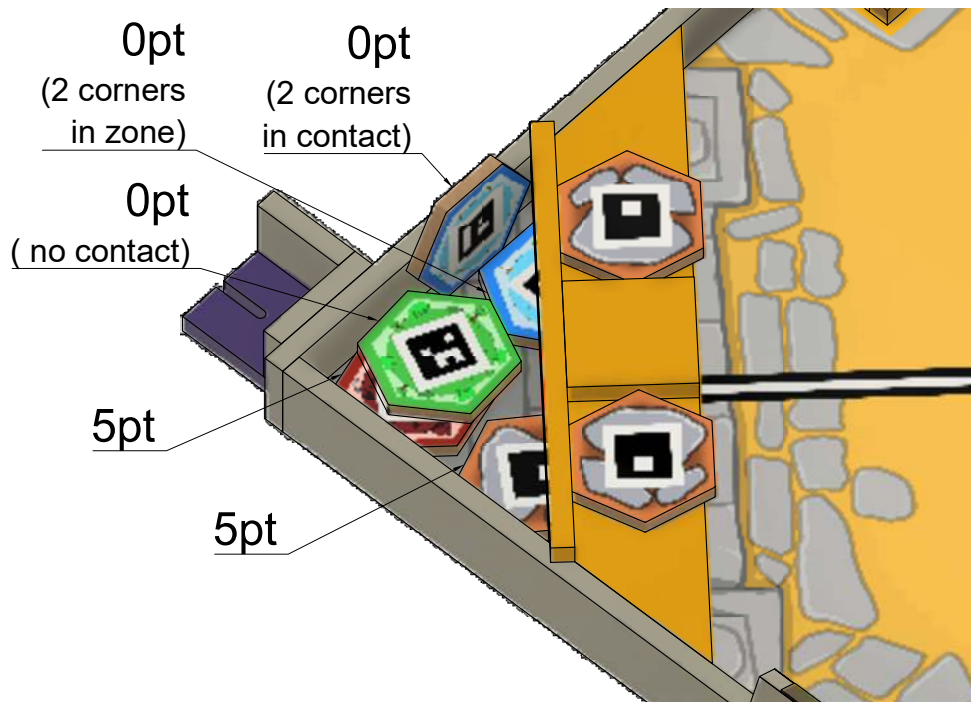

Figure 14 – Sample’s validity within the work shed

D.9. TO PRESERVE AND EXHIBIT THE STATUETTE

A statuette, a wonderful treasure of the history, was found by a previous expedition. To preserve it, the robots have to protect it from the elements and exhibit it in the display cabinet, and swap it with the replica on the original site.

D.9.a. DESCRIPTION AND LAYOUT OF THE PLAYING ELEMENTS

The statuette, replica, pedestal and display cabinet are used for this action.

D.9.b. ACTIONS AND CONSTRAINTS

Actions:

- The team has to put its statuette on its pedestal during the preparation time.
- During the preparation time, the team must preload the replica in one of those places:
 - in one of their robots;
 - in the display cabinet;
- During the match, the robots have to collect the statuette from the pedestal.
- Once the statuette has been collected, the robots have to put it in the display cabinet.
- The robots have to put the replica on the pedestal in place of the statuette.

Constraints:

- The replica and the statuette cannot be stacked.
- The replica is considered as valid on the pedestal only if it is on the pedestal at the end of the match.
- The replica is a cube of 60 mm of side made of wood with a maximum weight of 200 g.
- The statuette is considered as valid in the display cabinet when its entire volume is included in the dimensions of the display cabinet.

- The statuette cannot move by itself, neither inside the display cabinet nor on the playing area.
- The statuette built by the team has the following dimensional constraints:
 - It needs to fit inside a cube with 120 mm sides.
 - It needs to be larger than a cube with 60 mm sides.
- The weight of the statuette must not exceed 600 g.
- The statuette can incorporate a power supply. In this case, it must include an emergency stop button reachable at any moment.
 - It is tolerated to have a simple toggle switch as the emergency stop button.
 - The button must be visible and accessible by the referees at all times.
- A statuette still under a robot's control at the end of the match will not be counted.
- A replica still under a robot's control at the end of the match will not be counted.

D.9.c. POINTS

- **2 points** for installing the statuette on the pedestal during preparation time;
- **5 points** if the statuette is missing from the pedestal at the end of the game;
- **10 points** if the replica is on the pedestal at the end of the game;
- **15 points** if the statuette is inside the display cabinet at the end of the game;



Figure 15 – Displacements of the statuette and the replica

D.10. DISPLAY CABINET

D.10.a. DESCRIPTION AND LAYOUT OF THE PLAYING ELEMENTS

The display cabinet and statuette are used for this action.

D.10.b. ACTIONS AND CONSTRAINTS

Actions:

- The team must setup its display cabinet in the dedicated zone during the preparation time.
- The display cabinet will be activated during the match by placing the statuette inside it. The aim is to highlight the statuette with at least one luminous element.

Constraints:

- The activation of the display cabinet must be done at the moment the statuette is placed. The activation can be done by any means, wireless included.
- The display cabinet must have at least one luminous element activated by the statuette being placed. This element must be visible by the public but must not dazzle anyone. This luminous element can be contained inside the statuette, in this case the electrical supply must depend on the cabinet one.
- The display cabinet is considered as activated if it has clearly changed in form or aspect compared to the beginning of the match.
- The vertical projection of the display cabinet is not allowed to cross the limits of the exhibition hall at any time.
- The display cabinet has the following dimensional constraints (statuette included) :
 - Maximum depth : 222 mm.
 - Maximum width : 450 mm.
 - Maximum height : 430 mm.
- The weight of the display cabinet must not exceed 3 kg.
- The horizontal plane of the exhibition hall has a 10 mm wide groove running from the center of the support to the center of the back side. The groove must be used to fix the display cabinet to the exhibition hall by using a threaded rod of 8 mm diameter and a wing nut.
- Apart from the fixing screw and nut, no system or element of the display cabinet is allowed to protrude under the exhibition hall. The screw size is not counted in the height measurement of the display cabinet.
- The display cabinet must remain lit after the end of the match.
- The display cabinet can contain an electric power supply. In that case an emergency stop button which directly turns off the display cabinet must be present. The emergency stop button has the same specification as the emergency stop button of the robot. The switch must be visible, easily accessible and stay at the same height. The display cabinet can be powered before the match, without being activated.
- It is allowed to power supply the display cabinet by connecting it to the power supply of the control panel of the robot, but under no circumstances can the display cabinet be activated by the control panel. Connecting cables are not counted towards the dimensional constraints.
- The action must not be dangerous for the public, the peoples around the table, the playground or the robots.
- The display cabinet cannot be activated by an external element (team crew, remote control, ...)

D.10.c. POINTS

- **2 points** for installing a display cabinet during preparation time;
- **5 additional points** if the display cabinet is activated;

D.11. RETURN TO THE EXCAVATION SITE OR THE CAMP

D.11.a. DESCRIPTION AND LAYOUT OF THE PLAYING ELEMENTS

The campsites and excavation sites are used for this action.

D.11.b. ACTIONS AND CONSTRAINTS

Actions:

- After the end of the match the robot must be stopped in their own campsite or on excavation site on their side.

Constraints:

- To be considered valid a robots vertical projection must be at least partially inside the limits of the campsite or the excavation site.
- A team with multiple robots can only validate this action if both robots are in the campsite or the excavation site.

D.11.c. POINTS

- **20 points** if, at least, there is one robot in the camp or the excavating site;

D.12. ESTIMATE THE PERFORMANCE

D.12.a. DESCRIPTION AND LAYOUT OF THE PLAYING ELEMENTS

The device for displaying the score estimation during the match must be made by the team:

- It can be static (sheet of paper, slate, etc.).
- Or dynamic (electronic display); located either on the robot or on the display cabinet (please make sure that the display cabinet is activated).

D.12.b. ACTIONS AND CONSTRAINTS

- The team must evaluate the number of points scored in the match by its robot(s). For this, two exclusive options:
 - Pre-match evaluation on a static display: the team writes the score it intends to make during the match.
 - Evaluation during a match on a dynamic display device.
- The display area and its reading orientation must be easily visible and identifiable by the referees.
- The estimated score is an integer and must be expressed in decimal.
- It is allowed for a team with two robots to design a display for each robot. In this case, the score assessment will be the sum of the values of the two displays, or by a composition of the two display if the two robots are side by side at the end of the match; the type of reading and the order must be explained to the referees at the beginning of the match.
- In the case of dynamic displays, the estimated score must still be displayed after the end of the match.
- Under no circumstances should the score change once the match has ended, otherwise the bonus will be lost!
- In case of a dynamic display, the pilot control box can be used to update the display, but not to directly show the score.
- The copilot is not allowed to update the score estimation.

D.12.c. POINTS

The assessment is based on all the previous actions.

The estimation bonus is calculated as follows: **Bonus = (0.3 x Score) - Delta**

- The score is the one scored by the team during the match on standard actions.
- The delta is the difference between the score made by the team during the match and the score estimated by the team. This one is always positive (Absolute value).
- The bonus is an integer value (rounded up).
- The bonus is added to the points of the team.
- A negative bonus is reduced to 0.
- A score of zero cannot give right to any bonus.
- The bonus for not "forfeit" is not include in the performance estimation.
- The penalties are not include in the performance estimation.

E. PROJECT PRESENTATION

Both Eurobot^{Open} and Eurobot^{Open} Junior encourage participants to practice science in a funny and original way. Our main objective is to assist and value your projects conceived during the year. To achieve this, the teams must conceive a poster, and, organizers may require the teams to create a technical documentation of their robots.

We expect to see attractive, innovative robots that respect this edition's technical constraints and rules. Being creative and original will add value to your work as much as the performance of your robot(s) during the matches. By doing this presentation, you will increase the communication value of your project and the visual effect of your robots, for both the public coming to the events as well as for your own satisfaction. Having created something aesthetically and functionally complete, will strengthen your work attitude during and after the competition.

As in previous years, the presentation of your team's project (through project management on the long-term, task distribution ...) as well of your robots (technical systems implemented, chosen strategies ...) is an integral part of the event. Teams should present their projects in a way that is easily understandable and visible to the general public and the rest of the participants.

E.1. CONSTRAINTS

This presentation must be made on a panel size A1 (594 x 841 mm) at least. If you want to use other visual media than paper, it is quite possible. Let your imagination be free!

On the other hand, we advise teams to hold a blog explaining progressively the progress of the realization of their robot ("logbook"). The creation of this blog can be done automatically when the team register on our Poolzor software, and the procedure to be followed is explained in detail on the platform. A blog is not mandatory to validate the registration, but we strongly encourage teams to do so, in order to promote the exchange of ideas around their projects.

E.2. EVALUATION

The project must be exposed to the referees and / or guardian angels during the homologation of the robot to allow the teams to show all their work. This presentation will be taken into account in the homologation sheet.

During the meetings, a jury will pass through each panel and discuss with the teams to award a special prize for the best presentation. Team members must be able to present their project in English and/or in French, in order to compete for these prizes.

F. THE ROBOTS

F.1. FOREWORDS

Each team is allowed to register a maximum of two robots, called respectively "main robot" and "secondary robot". Each one have identical dimensional constraints. The set of both robots have additional dimensional constraints.

For Eurobot^{Open} Junior, the principal robot is wire-guided or remote controlled and the secondary robot is autonomous.

The construction of a secondary robot is optional. The aim is to allow teams with a large number of members to work on a second project. It is recommended for beginning teams to concentrate on building a single functional machine. Having one robot that works well is better than having two that do not move.

A secondary robot can compete only with the main robot with which it was designed and approved. However it can compete alone if the main robot cannot participate. It cannot be re-approved with another main robot.

A team's main or secondary robot must not block the other team's robots. In the event of a voluntary action of this type indicated by the referee, the team may be penalized.

A robot must not intentionally cause damage to the opposing robots or to the playing area and its elements.

Only two team members are allowed to enter the backstage and on stage. They transport all the equipment (robots, beacons, etc.). The path to the playground may include stairs, especially when entering the stage. It is therefore recommended to design easily transportable equipment.

The main and secondary robots must be made up of elements that are fixed to each other (so robots cannot leave parts or elements on the playing area), with the exception of the playing elements.

Robots must not attach themselves to the playing area (e.g. with a suction cup).

A robot must not prevent the opponent from scoring points. A robot that remains static (e.g. if it has finished all its actions) must move to a location that does not disturb the opponent, otherwise it risks getting penalties!

A game element can be moved:

- for the purpose of scoring points with;
- if justified by performing another game action (e.g. if a common game element is located on the robot's path). The number of elements that are then moved (especially from their position at the beginning of the game) must remain minimal.

Deliberately vibrating the table or any other irregular action exposes the team to a refusal of approval.

Each team must design a unique and original set of robots under risk of disqualification. It is therefore not allowed to design robots that are significantly similar to robots of other teams (e. g. identical rolling bases or actuators). In case of doubt, contact the refereeing committee.

Be imaginative! For example, as an innovation but also to offer the public and the media an attractive show, your robot can use sounds, display expressions, etc.!

F.2. DIMENSIONS

Warning: the dimensions of Eurobot^{Open} robots are identical to those of Eurobot^{Open} Junior. Eurobot^{Open} Junior participants can more easily access the Eurobot^{Open} meetings. The Eurobot^{Open} Junior robot will only need modifications to make it autonomous.

Dimensions of the robots :

The perimeter of a robot is the perimeter of the convex shell of its vertical projection on the ground. It is measured by surrounding it as shown in the illustrations below:

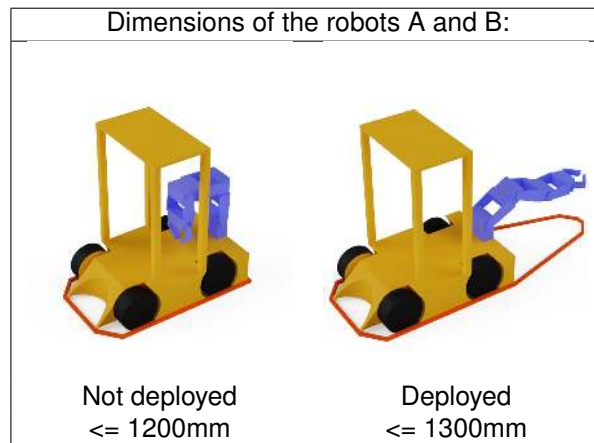

The perimeter of a robot must not exceed 1200 mm at the departure time. The perimeter of the fully deployed robot shall not exceed 1300 mm during the match. It is allowed to change the convex hull shape during the game, as long as the perimeter of this one always respects the maximum perimeter constraint.

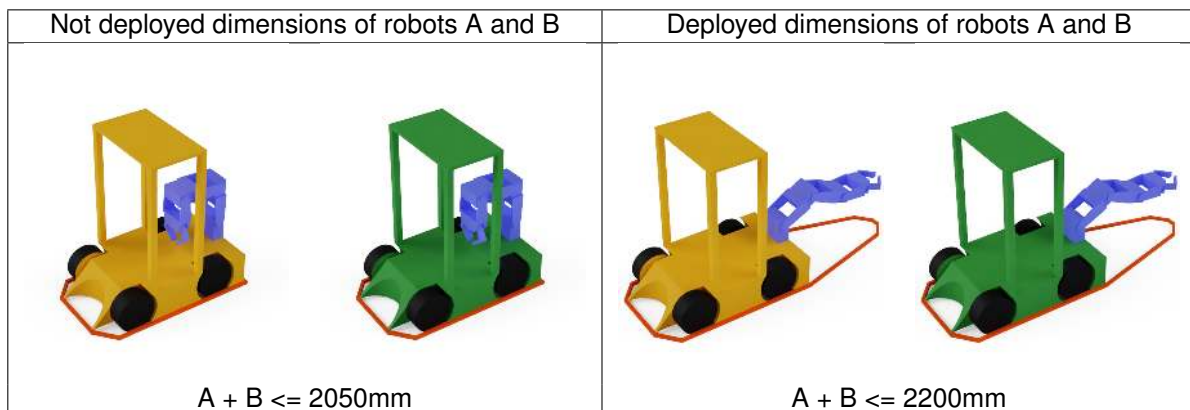

The sum of the perimeters of the two robots at the start of the match must not exceed 2050 mm. The sum of the deployed perimeters of the two robots must not exceed 2200 mm. Be careful, the sum of the deployed perimeters is equal to the sum of the maximum of the deployment perimeter of each of the two robots during the entire duration of the match. A robot cannot therefore reduce its perimeter during the match to allow a second robot to deploy more.

If a physical connection (mechanical, electrical, magnetic,...) exists between two robots of the same team, then the group formed by the two robots is in fact considered, for the perimeter constraints, as a single robot, until the group is dissociated. Note that a simple contact is not considered a physical connection.

At any time during the match the height of each robot must not exceed 350 mm. However, it can be tolerated that the emergency stop button exceeds this limit height to reach 375 mm.

F.3. ENERGY SOURCES

All potential sources of energy stored in the robots and other secondary systems are permitted (batteries, springs, compressed air, gravitational energy, etc.), with the exception of sources of energy using chemical reactions such as combustion or pyrotechnics processes, which are prohibited for safety reasons. It is obvious that the use of living beings is strictly forbidden.

In addition, the use of corrosive products is strictly prohibited and liquid splashes are not permitted.

If you have any doubt about unconventional energy sources, ask the referees' committee as soon as possible, providing the corresponding datasheets.

In order to avoid any risk of fire, attention should be paid to the diameters of the wires, depending on the intensity of the currents flowing through them. It is also strongly advised to protect the electrical installation with a fuse, wired close to the batteries.

Batteries:

If the team chooses a battery power supply, we remind that only unmodified batteries can be used.

Teams must be able to play three games in a row. Note that this includes the time required to set up, during which the robot will be powered and awaiting the start.

Therefore, we strongly recommend that teams bring several sets of batteries and provide easy access to them in the robot for their replacement. Teams are reminded that it is essential to have a set of spare batteries, fully charged and available at all times.

Note on the use of Lithium-based batteries:

Lithium batteries are known for their lack of stability and can easily ignite when certain precautions are not taken.

This type of battery is therefore authorized under the following conditions:

- Suitable battery charger, which must be submitted for approval.
- Batteries kept in certified and unmodified fireproof bags (whether in the robot or on the stand, even in storage).
- A system for detecting underloads is highly recommended.
- Exception in the case of the following batteries, authorized without the conditions listed above:
 - Lithium batteries for LEGO Mindstorm / laptop / mobile phone / power tools, provided that they have not been dismantled and are used for the intended purpose of the manufacturer.
 - Lithium-Iron batteries (LiFePo4)

Warning! The supply systems must be easily transportable. Teams may have to go up and down the stairs on their way to the stage where the matches take place.

The power source transmitted to the robot can only be electric. The maximum permissible voltage is 13.8 V (measured between any two wires of the cable and the robot). This voltage source is not provided on the day of the meeting. On the other hand, the teams have access to the standard (230 V 50 Hz standard) and can use batteries.

The terminals of the cables must be insulated.

F.4. OTHER DESIGN CONSTRAINTS

Visibility: A rectangular space of 100 x 70 mm per robot must be left free on one of the side faces. As far as possible, this space must be visible from a camera located at the height of the playing field. It must also be visually accessible during the majority of the match. The teams will receive stickers printed by the organization

(team number, sponsors etc), which they have to place on these open spaces.

Teams are strongly encouraged to make all element manipulations visible from the outside. By doing this, you allow the audience and the cameras that film the event to see how the transport of your game elements works.

Starting cord of autonomous robots: Robots must be equipped with a starting device easily accessible. This device has to be triggered by pulling the end of a cord at least 500 mm long. This cord must not stay attached to the robot after departure.

No other starting system (remote control, manual rocker switch, etc.) will be approved.

The start of one robot can launch the other robot.

Emergency stop button of autonomous robots Autonomous robots must be equipped with a red emergency stop button of at least 20 mm in diameter. It must be placed on the top of the robot in a visible position and in a non-risking area to be immediately accessible by the referees at any time during the match.

In its higher state, the button may exceed the robot's height by 25 mm. The emergency stop button must be operated by a simple downward movement (for example, by hitting it with the fist).

Pressing this button must stop all robot actuators immediately !

Automatic shutdown Each robot must be equipped with a system that stops the movement of the robot and all its actuators automatically at the end of the 100 seconds (a match's duration). The dynamic displays that are present on the robots, can remain on.

The automatic shutdown of the robot (s) is optional for participants in Eurobot^{Open} Junior.

Avoidance system (optional for Eurobot^{Open} Junior) Robot(s) avoidance systems are optional for Eurobot^{Open} Junior participants.

Warning: As most of the events are filmed, please adapt your avoidance systems so that it is not disturbed by autofocus cameras and filming.

Control system For the main robot, each team must have a control console operated by a single driver.

It is authorized to pilot your main robot by a wireless remote control. Both solutions, wired and wireless, are allowed this year. Please, read the next paragraphs to know the conditions.

F.4.a. THE WIRE CONTROL SYSTEM

The control system It's the housing used for controlling the electrical devices of the robot. It is connected to the robot only by an electric cable. Any other communication type system between the robot and the outside, is strictly forbidden.

F.4.b. THE WIRELESS CONTROL SYSTEM

It is a housing for controlling the controlled robot's electrical devices. It communicates with the robot using wireless equipment. It can be connected to the robot by an electric cable to power it. The wireless control system should only be used for communication between the pilot and the robot. Under no circumstances should it be used to communicate with the outside world during matches.

To avoid interference problems with another team, the public or the equipment used by the organizer, it is strongly recommended that a team choosing a wireless control system be able to quickly change the frequency and/or communication channel. Under no circumstances may the team contest the inconvenience caused by possible interference.

F.4.c. THE CABLE

The electrical cable connecting the robot to its control system is not provided: it must be designed and implemented by each team, according to its needs.

The robot executes a lot of movements on the playing area, therefore the cable must have a minimum length of: two meters between the power outlet and the power supply and five meters between the robot and the control box.

The cable must come out from the top of the robot, so that it does not touch the playing area.

It is held in the air by the co-pilot using a pole provided by the organizers.

During the match, the co-driver must not interfere in the control or in the settings of the robot (supply voltage for example). Consequently, the departure of the secondary robot can only be triggered by the pilot.

The cable must not be used to guide the robot, or direct it in case of reversal. Penalties can be given to co-pilots that use the cable to guide their robot !

F.4.d. THE CONTROL SYSTEM FOR THE AUTONOMOUS SECONDARY ROBOT

Teams can use any kind of control system for the robot (analog, microprocessor-based, microcontroller, embedded computer, programmable logic, etc.).

These systems must be fully integrated into the secondary robot.

The control system must allow the robot(s) to play a match with either one of the colors provided to teams. Ideally, it should be configured shortly before the match with any of the two colours.

Wifi networks:

At multiple contest locations, the number of active Wifi devices can disturb the robots implementing this technology for communication. To answer this issue, it's recommended (but not mandatory) to use the 5 GHz frequency rather than the 2.4 GHz one.

F.5. SECURITY CONSTRAINTS

F.5.a. GENERAL ASPECTS

All systems (robots and accessories) must comply with the European standards. This is also mandatory for the countries outside the EU that are organizing national meetings or send independent teams for the European Finals. Among other things, these security standards must respect safety rules and must not endanger participants, organizers nor public.

Robots must not have protruding or pointed parts that could be dangerous or cause damage.

The use of liquid, corrosive, pyrotechnic and living beings is prohibited.

All robots must comply with standard "low voltage" regulations. As a result, **the on-board voltages must not exceed 48 V.**

Potential differences greater than 48 V may exist, but only within closed commercial devices (eg lasers, LCD backlights, etc.) and only if these devices have not been modified and comply with national and European regulations.

In general, any system deemed by the referees' committee as dangerous will not be approved, and must be replaced, in order to be accepted in the competition.

F.5.b. LASERS

Only laser systems and classes defined according to the IEC60825 international standards are accepted. Teams using lasers must provide the manufacturer's document mentioning **the class of the device** (this information is normally always available on the system itself).

On the basis of this classification, class lasers:

- 1 and 1M are accepted without restriction
- 2 are tolerated only in case the laser beam do not exceed the play area
- 2M, 3R, 3B and 4 are strictly forbidden.

WARNING: Disassembling or modifying devices using laser sources often results in a change of class. Laser devices must not be altered and only be used in the state of their commercialization (laser device = source + optics + electronics).

F.5.c. HIGH POWER LIGHT SOURCES

When using a high intensity light source, the light intensity must not be dangerous to the human eye in case of direct contact. Note that some types of LEDs have warnings. Be responsible, as your machines are evolving in front of a general audience!

In the case of slightest doubt, the organization reserves the right to request the manufacturer's specifications to verify the non-dangerous nature of the lighting system used. If it turns out that the system is potentially dangerous, it may result in revocation of lasers class 2M and more.

F.5.d. COMPRESSED AIR SYSTEMS

Compressed air systems should not exceed 4 bars, except in pre-assembled commercial products, and only if :

1. these devices have not been modified.
2. They are compliant with european safety regulations.
3. they are safe.

The use of pressurised gas cartridges such as CO2 cartridges is prohibited

G. MATCHES

The matches have a duration of 100 seconds.

Only two persons per team are permitted to go backstage and on stage to play the matches.

To ensure that the contest runs smoothly, we ask the teams to be present on their booth with the robot(s) and ready to go 30 minutes before the start of the series and until that the game is played.

In case of a problem, it is tolerated by the organization to ask for a delay to go to the match but this delay can never exceed the end of the current series. If the team cannot do its match before the end of the series, a forfeit will be applied. In case of abuse, a warning will be applied, and if the problem recurs in a subsequent series, a penalty may be awarded.

In any case, the team must be present on its booth when the organization comes to pick it up for a game. In the event of non-compliance with this rule, an official may initially give the team a warning, and if the absence is repeated on a subsequent series, a penalty may be awarded.

G.1. PREPARATION TIME

At the start of a match, the elements of the playing area and the playing area itself are installed as indicated in the diagrams in the appendix.

Upon arrival on the playing area, each team has a maximum of three minutes to proceed with the placement of the robots and other equipment.

A robot which is not ready at the end of this period exposes the team to a forfeit for the match.

Besides, the other team's robots will still play their own game on the playing area. The team will have to score points to be declared the winner.

When both teams have finished setting up, or when the preparation time is over, the referee asks the participants if they are ready. From this moment, teams are no longer allowed to touch their robots. No dispute can be made on the disposition of the elements of play after the beginning of the match.

G.2. THE MATCH

At the signal of the referee, each robot is switched on. In no case may robots, playing elements and playing area be allowed to be touched during the match. In case of absolute necessity, the referee may authorize such action.

Any manual intervention on a robot, a playing element or the playing area, without the explicit authorization of the referee, may justify the application of a forfeit or a penalty for the match.

No elements taken out of the playing area can be put back on the table before the end of the match and the validation of the scores.

At the end of the match, the robots must stop and turn off all their actuators. It is allowed to keep on any dynamic displays.

At the end of the match, **no one except the referee** can touch the robots and the playing elements unless expressly indicated by the referees. The referees count the points; they give the result of the match, including the points to the teams. If they both agree, they validate the match sheet, can take back their robot(s) and join their booth. If the teams do not agree, they refer calmly to the referees. The robots remain in place until the dispute is resolved. Refereeing decisions are final.

In the event of a situation that is difficult to judge, the referees reserve the right to decide whether or not to

replay the match.

The referees are allowed to pronounce the end of a game in advance, before the end of the regular time if both teams agree (if the robots are blocked for example).

A team is considered to be **forfeit** for the match:

- if none of the robots have completely left the starting area during the match,
- following refereeing decisions.

Pressing the emergency button of a robot during a match may expose the team to a penalty or a forfeit.

G.3. COUNTING POINTS

At the end of the match, the referees count the points of each team according to the following.

Points summary

G.3.a. FINDING EXCAVATION SQUARE

- **5 points** for each revealed excavation square at the team's colour;
- **5 points additional** if at least an excavation square at the team's colour is revealed, and the red square at the team's side is not revealed;

G.3.b. RESEARCH AND ANALYSIS OF SAMPLES AT THE CAMPSITE

- **1 point** for each sample removed from a distributor on the team side (including the shared distributor and the work shed);
- **3 points** for each sample inside the gallery;
- **3 additional points** for each revealed and sorted sample inside the gallery;
- **1 point** for each sample inside the camp;
- **1 additional point** for each revealed and sorted sample inside the camp;

G.3.c. STORING SAMPLES IN THE WORK SHED

- **5 points** for each sample inside the work shed;

G.3.d. RETURN TO THE EXCAVATION SITE OR THE CAMP

- **20 points** if, at least, there is one robot in the camp or the excavating site;

G.3.e. TO PRESERVE AND EXHIBIT THE STATUETTE

- **2 points** for installing the statuette on the pedestal during preparation time;
- **5 points** if the statuette is missing from the pedestal at the end of the game;
- **10 points** if the replica is on the pedestal at the end of the game;
- **15 points** if the statuette is inside the display cabinet at the end of the game;

G.3.f. DISPLAY CABINET

- **2 points** for installing a display cabinet during preparation time;
- **5 additional points** if the display cabinet is activated;

G.3.g. ESTIMATE THE PERFORMANCE (BONUS POINTS)

The assessment is based on all the previous actions.

The estimation bonus is calculated as follows: **Bonus = (0.3 x Score) - Delta**

- The score is the one scored by the team during the match on standard actions.
- The delta is the difference between the score made by the team during the match and the score estimated by the team. This one is always positive (Absolute value).
- The bonus is an integer value (rounded up).
- The bonus is added to the points of the team.
- A negative bonus is reduced to 0.
- A score of zero cannot give right to any bonus.
- The bonus for not "forfeit" is not include in the performance estimation.
- The penalties are not include in the performance estimation.

Warning! An element controlled by a robot, does not yield points. An element is considered to be controlled by a robot, if by moving the robot along its natural axis of movement the element is moved.

G.3.h. THE PENALTIES

A penalty is a **loss of 20 points** on the result of the match. Several penalties can be applied.

A negative score will be reset to 0.

RECALL:

The penalties are intended to compensate for damage after a possible incident during the course of the game. A penalty situation is considered as non-respect of the rules of the game, this type of situation must remain exceptional!!! A penalty may result in the team's forfeit. The referees' committee will also be attentive to the penalties distributed between several levels of meeting (regional/national/European).

G.3.i. BONUS POINTS

1 bonus point is awarded to all teams that are not "forfeit", this point is not included in the performance estimation.

G.3.j. FORFEIT CASES

The score of a forfeit team is reset to zero.

H. THE CONTESTS

H.1. GENERAL INFORMATION

The Eurobot^{Open} Junior meetings can be organized on three levels:

- regional: when they exist (e.g. in France, Eurobot^{Open} Junior), qualify a number of teams for the national meeting,
- national: it allows to qualify the teams for the European meeting,
- European: this last stage brings together, in the same friendly spirit, teams from different countries in Europe and elsewhere.

Each meeting has several successive steps:

- The static and dynamic approvals of all the robots;
- A qualification phase;
- An optional play-off phase;
- A final phase.

H.2. APPROVAL

H.2.a. STATIC APPROVAL

Before the start of the matches, robots are subject to the supervision of a referee who checks their compliance with the rules. Robots must be able to easily show all their mechanisms.

The ancillary systems (accessories, control panel, etc.) will also be subject to static control (size, mass, presence of mandatory elements, etc.).

H.2.b. DYNAMIC APPROVAL

The robots must, within 100 seconds, validate at least one action. The robots are put in a game situation but without the presence of an opposing team. Certain specific features provided for in the regulation can also be checked (timer, avoidance of opponents, etc.).

If the assembly consisting of the main robot and the optional secondary robot fulfills these conditions, it is declared approved.

H.2.c. SIGNIFICANT TECHNICAL MODIFICATIONS AFTER THE APPROVAL

It is essential to inform the referees of any significant modifications (functional, structural, dimensional ...) brought to the robot(s) or any other element after approval. The referees will then check the modifications made and re-approve the robot if they deem it necessary. In the event of a breach, the team may be declared disqualified from the contest.

H.3. QUALIFICATION PHASE

During the qualification phase, the registered teams will have the possibility to play at least three games (often more, depending on the local organizers).

A ranking is established according to the accumulated points in order to select the qualified teams for the next phase.

The tied teams are tied by comparing their scores without taking into account their bonus points. Organizers may also use additional matches.

At the end of the qualifying phase, the 4, 8 or 16 first teams (according to the matches) are qualified for the next phase.

H.4. THE PLAY-OFF PHASE

An additional play-off phase may set up in the event that a meeting hosts two contests, the first of which qualifies for the second. For example:

- a regional meeting (A) and its national meeting (B)
- or a national meeting (A) and the European meeting (B)

The organizer may carry out the qualifying phase of both matches (A) and (B) either in parallel fashion or in a mixed fashion. In this case, a play-off phase may be organised in order to allow teams from the match (A) to qualify for the match (B), exempting them from having to catch up on all the matches from the qualifying phase of (B) in favour of this play-off phase.

The teams participating in this play-off phase are:

- the teams of the match (A), in a number corresponding to its qualification quota, and chosen in the order of ranking at the end of the qualification phase of (A) or through the award of a jury prize.
- the teams of the match (B), in a number equivalent to the participants in this phase from (A), chosen from among the last teams normally qualified for the final phase of the match (B).

Example for a national meeting qualifying three teams for its European final with two teams qualified in the ranking and one per jury prize and whose European final phase has 16 teams. The teams participating in the play-off phase are:

- **the first two teams of the national meeting at the end of the final phase of the national meeting, as well as the team that received the jury prize;**
- **and the teams ranked 16th, 15th and 14th in the qualifying phase of the European meeting.**

In this play-off phase, one match will be played for each participating team. The participating teams from the match (A) qualified through the ranking will play, in order of their ranking, with the teams from the match (B) with the lowest ranking. And the team(s) of (A) qualified for this play-off phase through a jury prize will play against the top-ranked teams of (B) in a random order.

Each team that wins its play-off match will be included in the main draw of the final phase of the match (B). At the end of the play-off phase, the tree of the final phase of the match (B) presented in Figure 16 may be revised to more accurately represent the level of each team.

H.5. THE FINAL PHASE

At the end of the previous phase, the qualified teams form the table of the matches of the final phase.

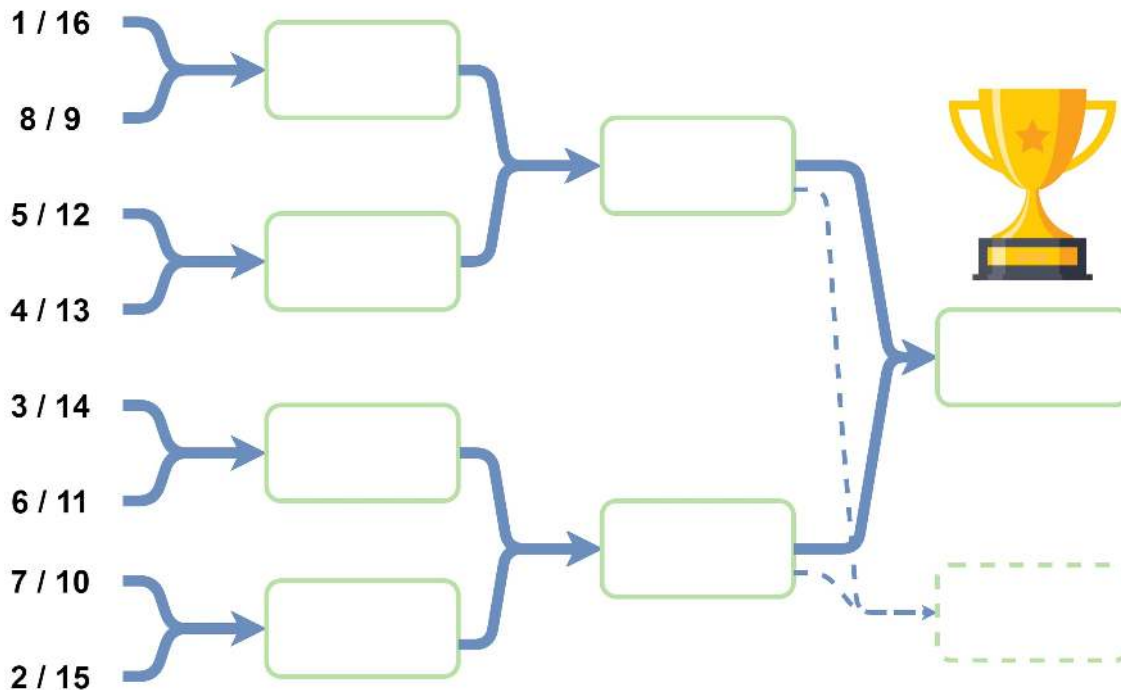

Figure 16 – Tree of the final phase

The matches of the final phase are with knockout, unless otherwise organized on some meetings. In the event of double forfeit, double defeat or tie, the match is replayed immediately; if this second match is still a case of double forfeit, double defeat or equality, the winner is determined according to the points acquired at the end of the qualifying phase.

The final is played in two winning games. Be careful to provide batteries accordingly for autonomous robots.

H.6. QUALIFICATION FOR THE NATIONAL MEETING

When there are regional meetings, the number of teams qualified per regional meeting is proportional to the total number of teams registered at the national level.

The best teams in the ranking established at the end of the qualifying phase of each regional meeting, as well as at least one team chosen by the organizers from the special prizes (e.g. creativity, fair play, presentation, etc.).

H.7. QUALIFICATION FOR THE EUROPEAN MEETING

Each country participating in Eurobot^{Open} Junior organizes a national meeting to determine the qualified teams for the international meeting.

The top teams in the final rounds (and not the qualification rounds) as well as the team who receives a special award will qualify for the European meeting. The number of qualified teams per country is proportional to the total of international registered teams.

For questions and comments, feel free to visit the Planète Sciences Forum.

<http://www.planete-sciences.org/forums/>

News and more information about Eurobot^{Open} and Eurobot^{Open} Junior are available on our website

www.eurobot.org

(It also contains links to your local organization)

The whole organization team of Eurobot^{Open} and Eurobot^{Open} Junior wishes you a lot of fun and success in the coming months, and looks forward to seeing you soon around our playing areas!

Robotic Regards,

The Eurobot^{Open} Eurobot^{Open} Junior organization committee.

I. APPENDIX

I.1. GENERAL DRAWINGS

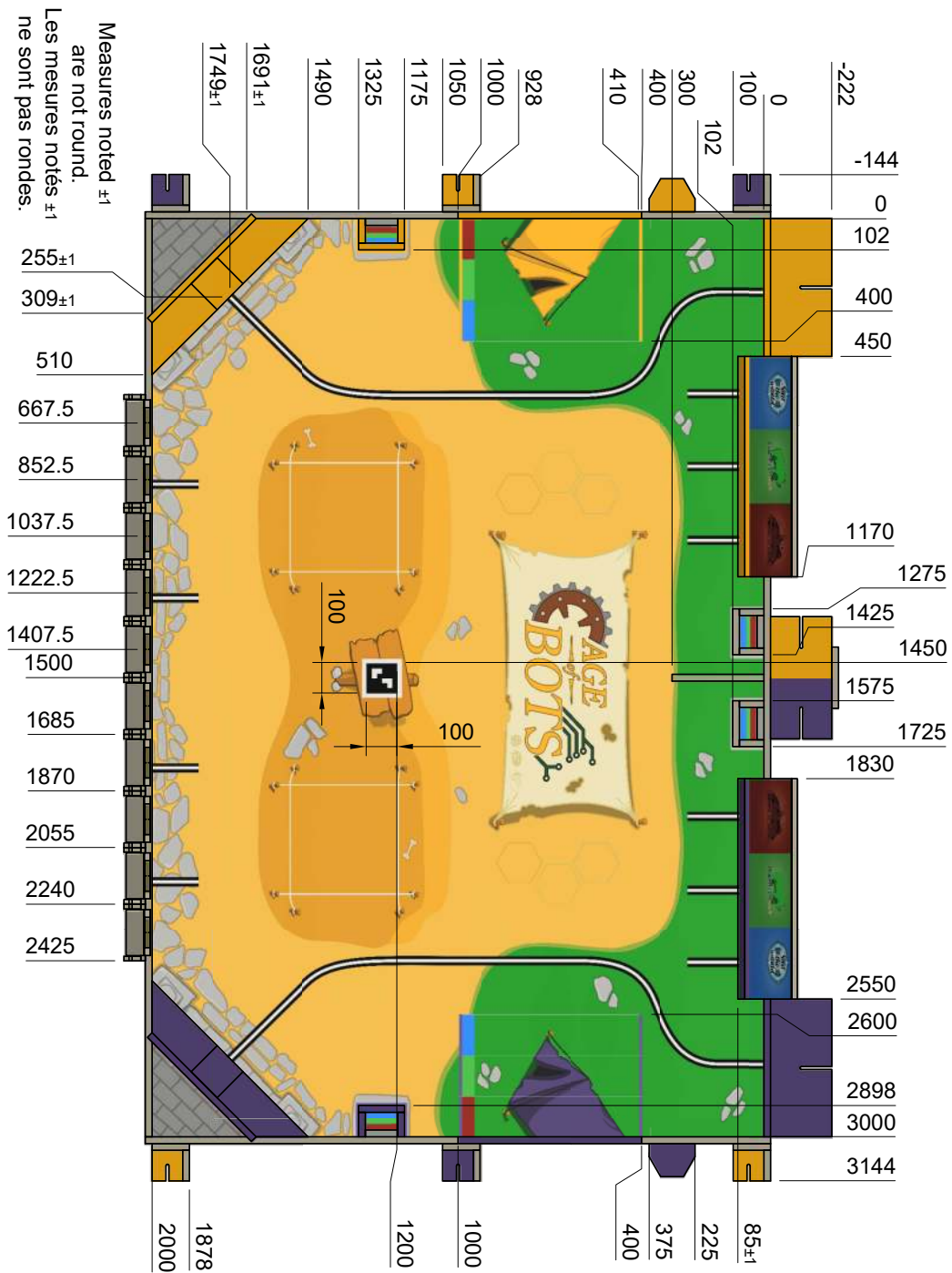

Figure 17 – Top view of the playing area without the samples

I.1.a. SAMPLE

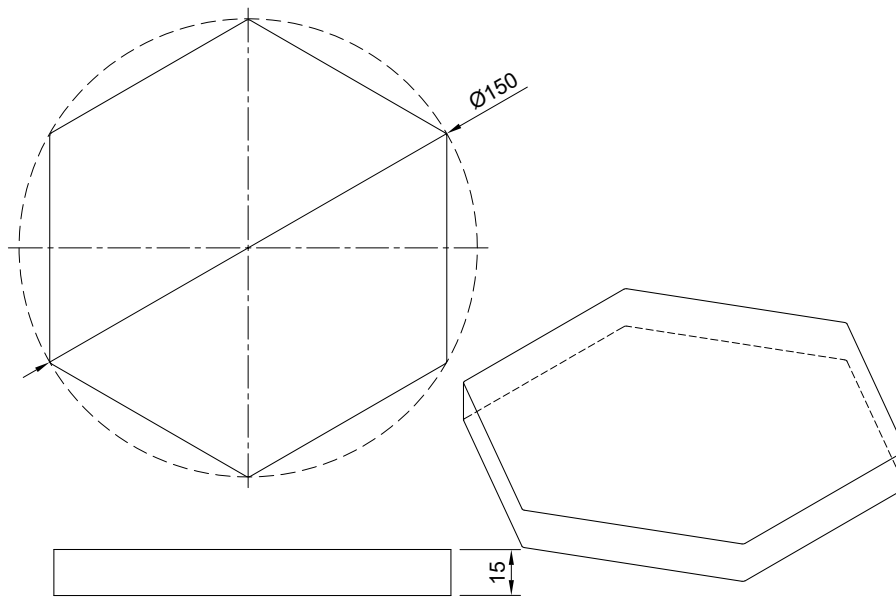

Figure 19 – Sample

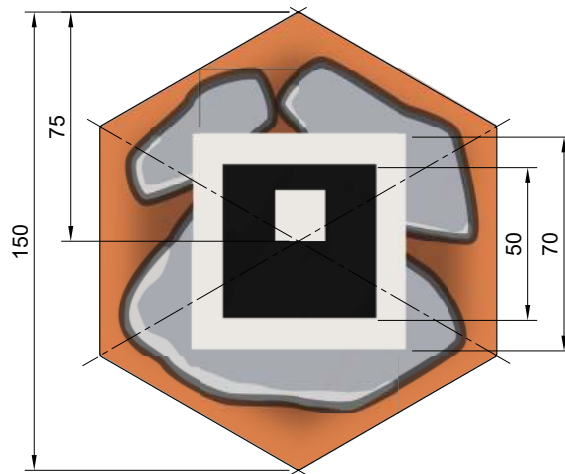

Figure 20 – Sample and ArUco tag

I.1.b. EXHIBITION GALLERY

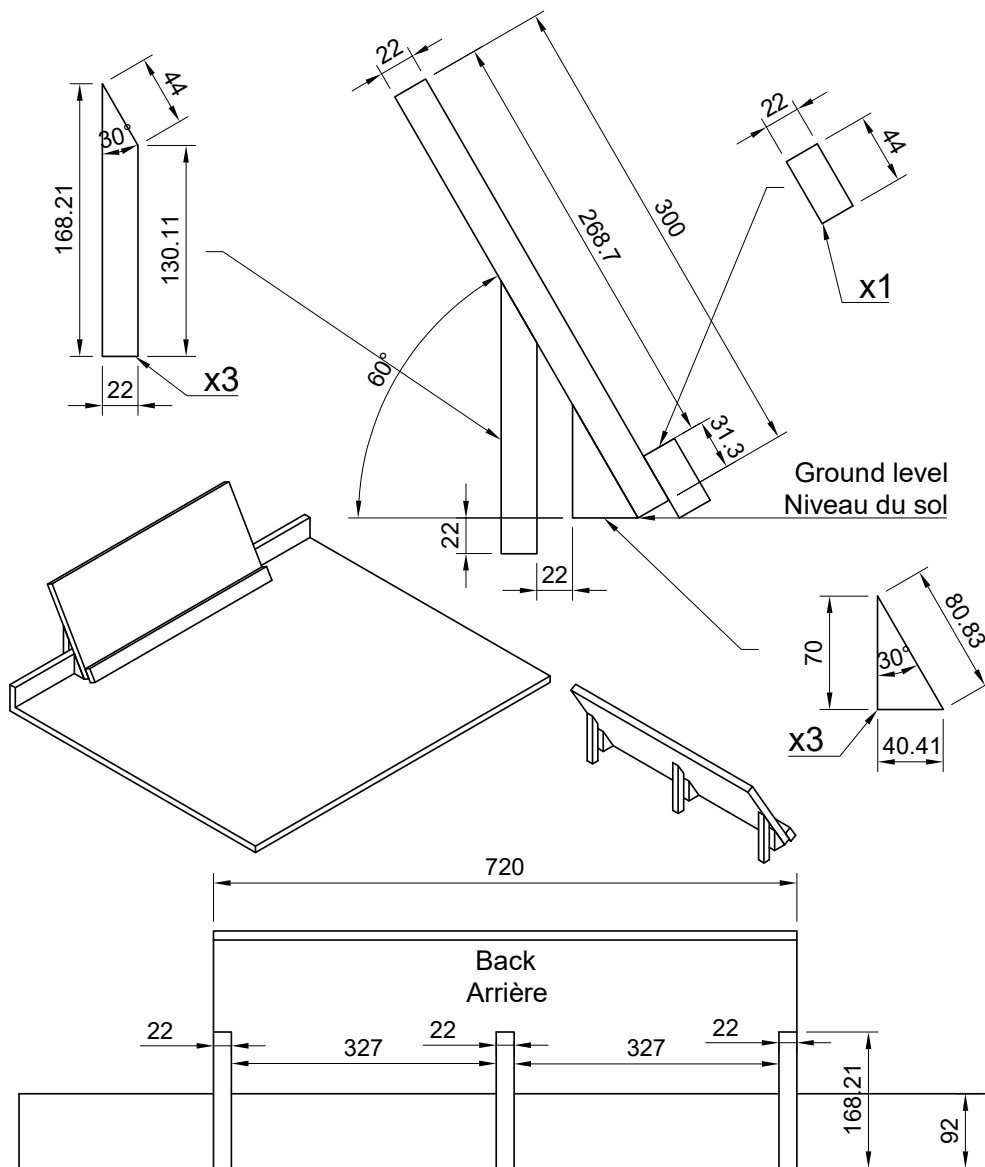

Figure 21 – Exhibition gallery

I.1.c. SAMPLE SUPPORT

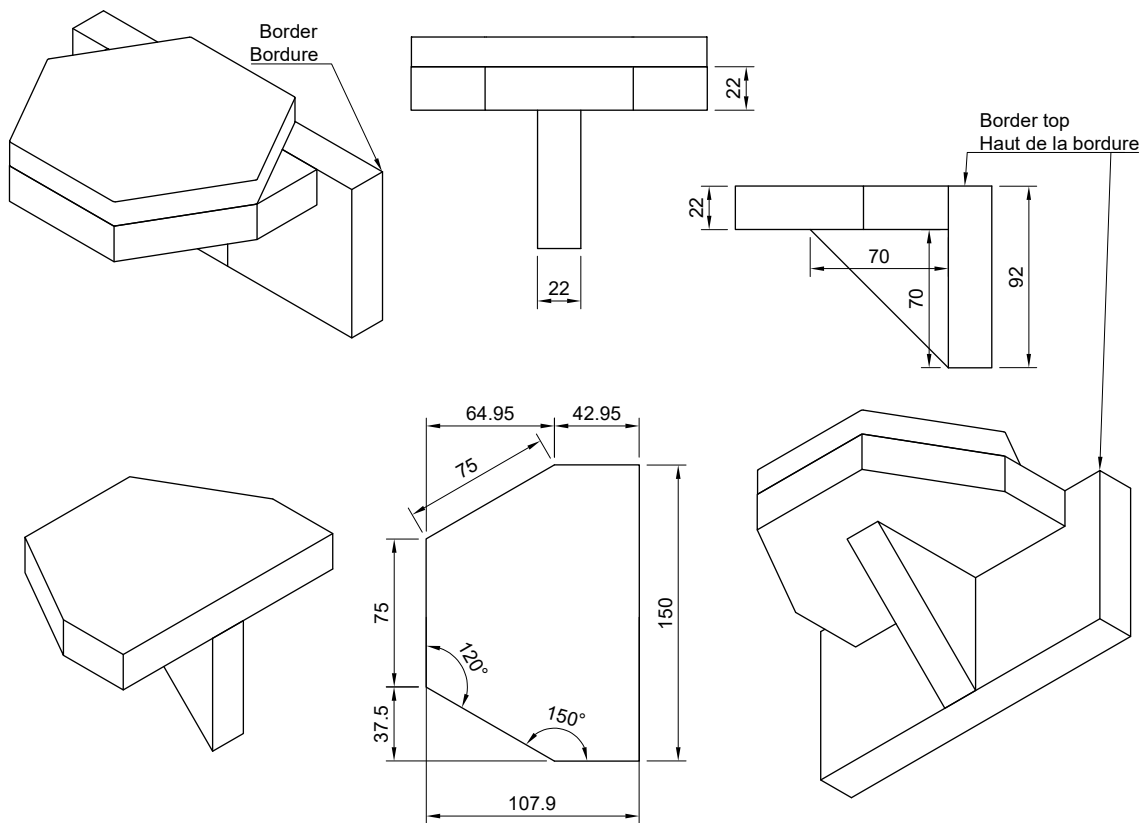

Figure 22 – Sample support on side

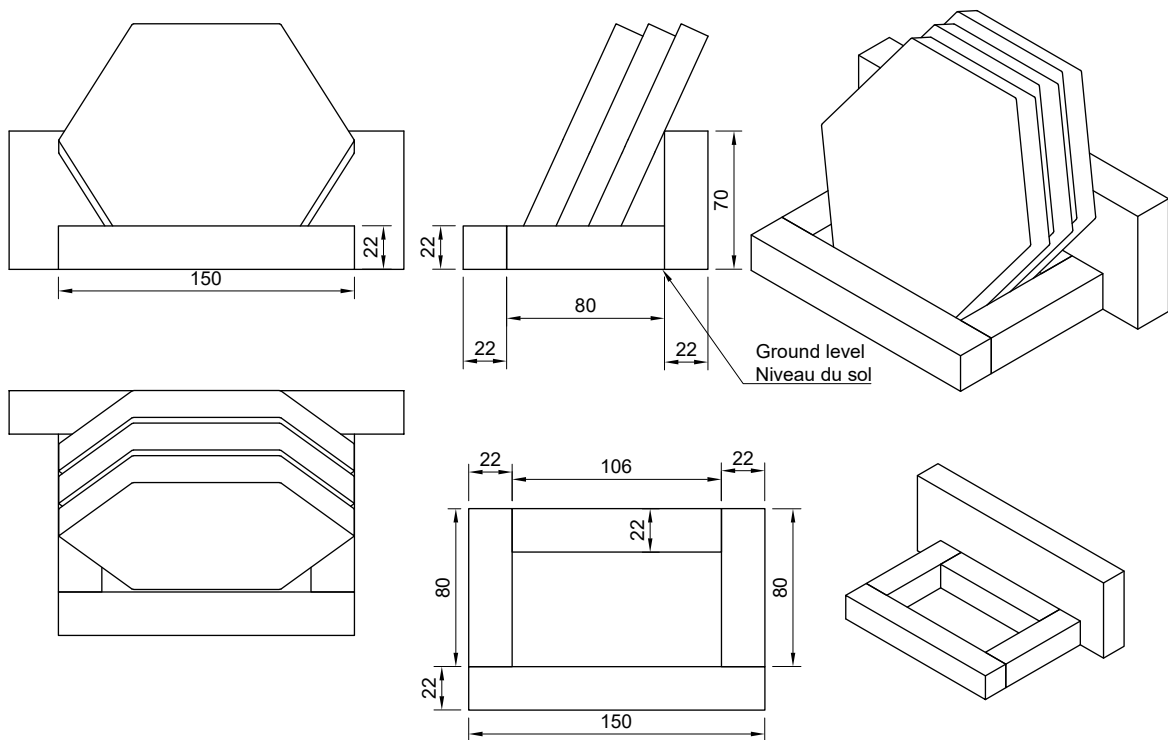

Figure 23 – Sample support on table

I.1.d. DISPLAY CABINET

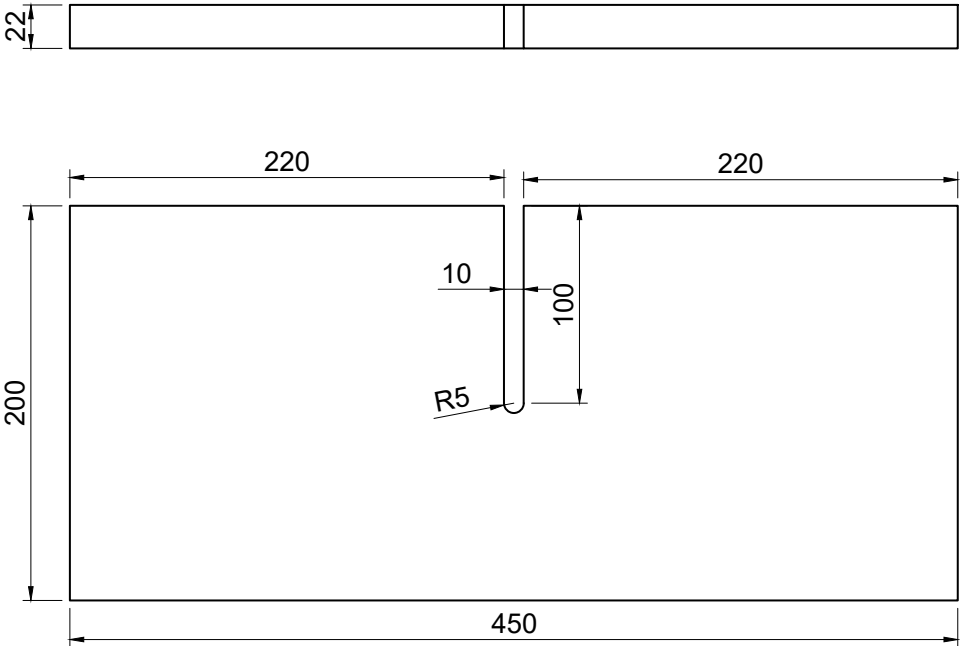

Figure 24 – Display cabinet

I.1.e. STATUETTE SUPPORT

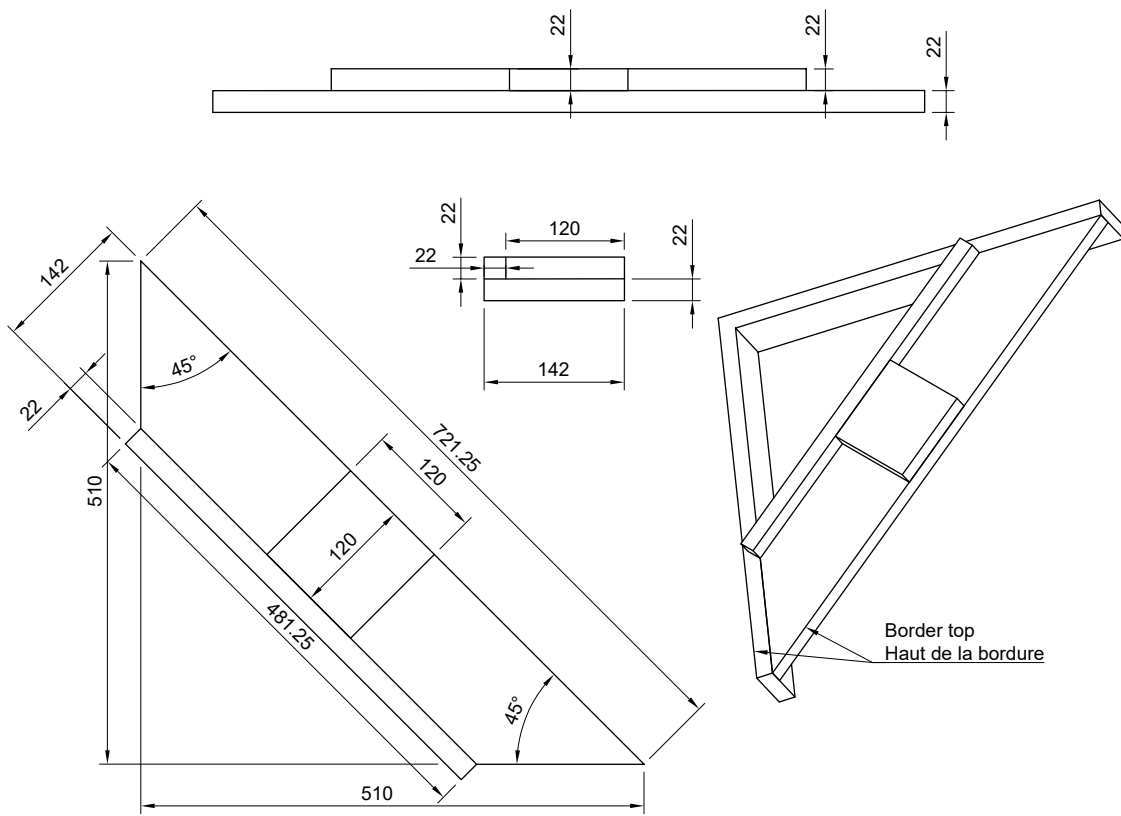

Figure 25 – Statuette support

I.1.f. EXCAVATION SQUARE

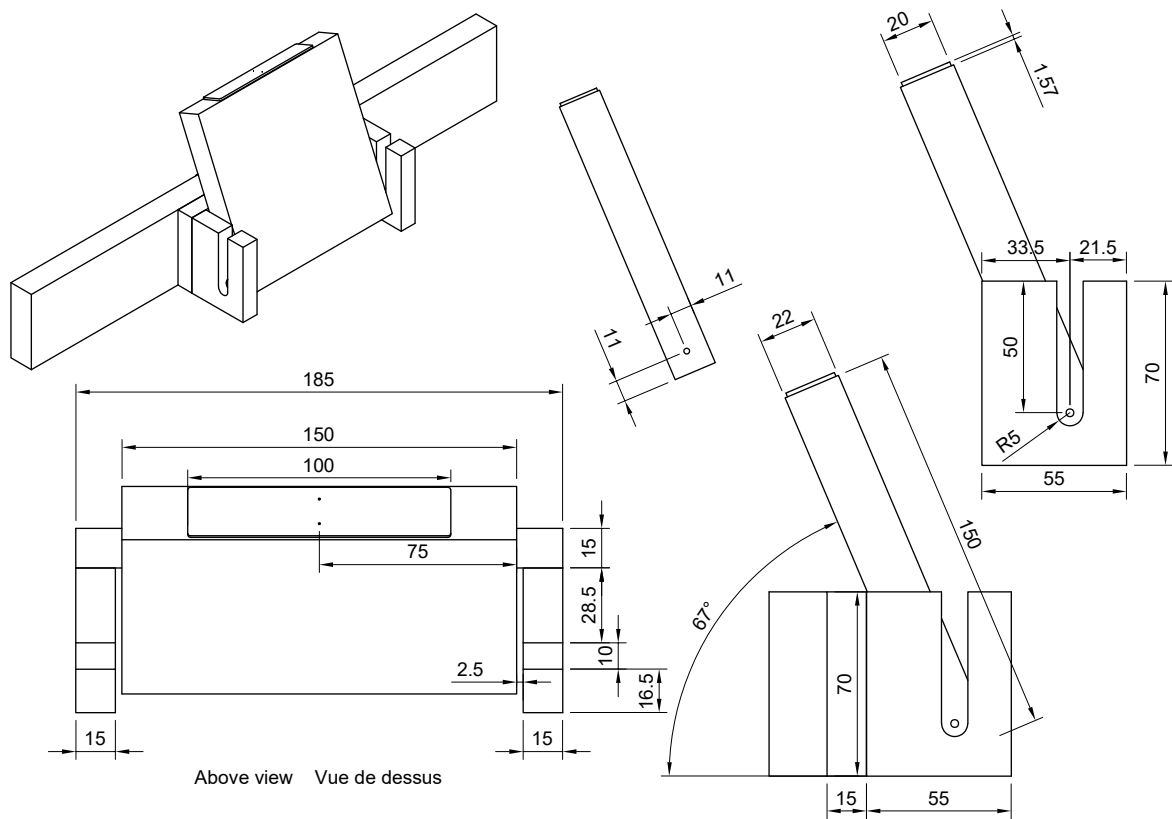

Figure 26 – Excavation square

Notice: the inner faces is covered by a vinyle whereas the slices and the outer face are painted in grey. A wood screw is recommended for the rotation axis of the excavation square, however this choice is left to the organization.

I.1.g. GALLERY SPLIT CLEATS

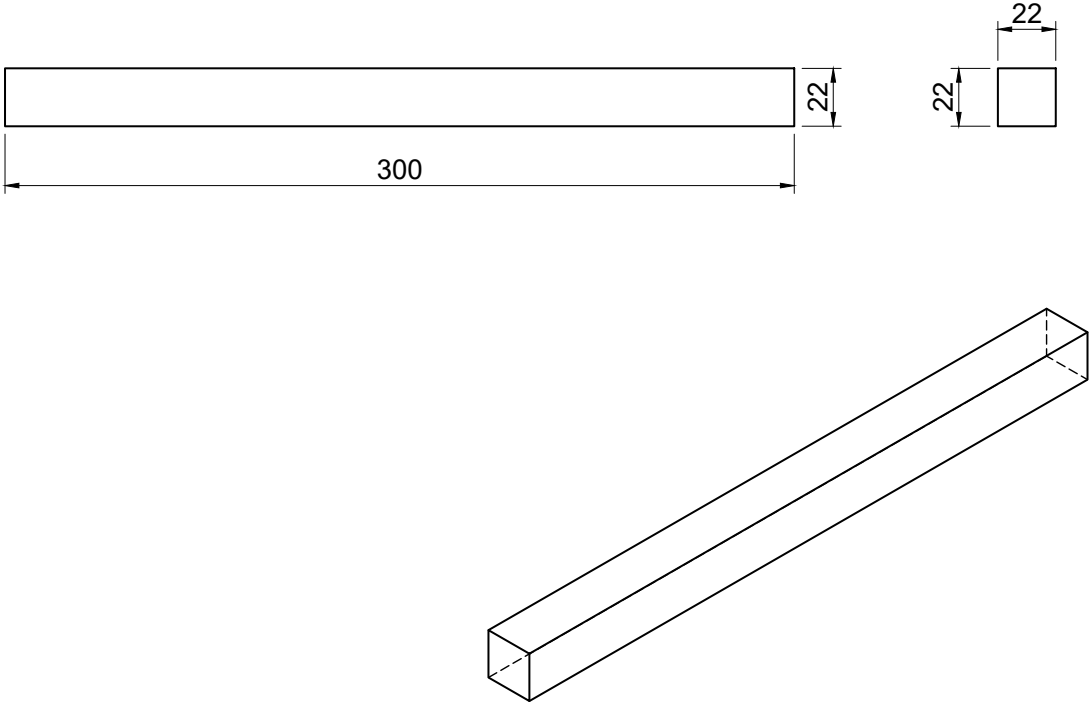

Figure 27 – Cleat

I.2. MATERIAL REFERENCES

Elements	Material or reference	Comments
Samples	Wood - Printed monomeric gripping vinyl	
Game floor	Printed monomeric gripping vinyl	Ordering information will be provided by Planète Sciences
Replica	Wood	
Showroom	Wood	
Central separators	Wood	
Distributors	Wood	
Excavation square	Wood - Printed monomeric gripping vinyl - Printed circuit	Ordering information will be provided by Planète Sciences or in Annex
Robot identification marker	Polystyrene - Plastic - Vinyl - Velcro TM	

I.3. MANUFACTURING TOLERANCES

All dimensions are in millimeters (or mm). Manufacturing tolerances shall comply with the following rules, unless otherwise specified directly on the drawings.

Dimensions	General Tolerances
≤ 20	± 1.50
> 20 and ≤ 70	± 2.50
> 70 and ≤ 150	± 4.00
> 150	± 5.00

No objections regarding differences in dimensions will be taken into account.

The material's density can change from one country to another. It is highly recommended that the teams try different types of wood since the weight may differ significantly.

I.4. COLOUR REFERENCES

	Colors	References	CMYK
Team purple	Signal Violet	RAL 4008 Mat	50% , 90% , 0% , 5%
Team yellow	Traffic yellow	RAL 1023 Mat	0% , 25% , 100% , 0%
Borders and non-colored elements	Pebble grey	RAL 7032 Mat	15% , 10% , 25% , 20%

RAL hues can vary from a printed soil mat to another.